

EDS94AYFLF
13279709

L-force Drives

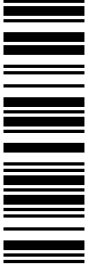

Software Manual

9400



Digital frequency extension module (E94AYFLF)

Parameter setting & configuration

Lenze

Overview of the technical documentation for Servo Drives 9400

Project planning, selecting & ordering

- 9400 Hardware Manual
- Catalogue / electronic catalogue (DSC - Drive Solution Catalogue)

Mounting & wiring

- MA 9400 HighLine/ServoPLC
- MA for communication module
- MA for extension module
- MA for safety module
- MA for accessories
- MA for remote maintenance components

Parameter setting

- BA keypad
- SW for Lenze »Engineer« software
- SW for controller (9400 HighLine/ServoPLC)
- SW for regenerative power supply module
- KHB for communication module
- SW for extension module**
- SW for safety module
- SW for Lenze technology application
- SW 9400 function library

← This documentation

Configuring

- SW for Lenze »Engineer« software
- SW for controller (9400 HighLine/ServoPLC)
- KHB for communication module
- SW for extension module**
- SW for safety module
- SW for Lenze technology application
- SW 9400 function library

← This documentation

Commissioning of the drive

- Commissioning guide
- SW for controller (9400 HighLine/ServoPLC)
- Remote Maintenance Manual

Networking

- KHB for communication medium used

Legend:

- Printed documentation
- Online documentation (PDF/Engineer online help)

Abbreviations used:

- BA Operating Instructions
- KHB Communication Manual
- MA Mounting Instructions
- SW Software Manual

Contents

1	About this documentation	5
1.1	Conventions used	6
1.2	Terminology used	7
1.3	Definition of notes used	8
2	Digital frequency input	9
2.1	Terminal assignment X9	9
2.2	Parameter setting	10
2.2.1	Signal form configuration	11
2.2.2	Encoder signal detection	12
2.2.3	Position setting	12
2.2.4	Use of machine parameters for scaling	13
2.2.5	Voltage control - TTL encoder	14
2.2.6	Monitoring	14
2.2.7	Touch probe	16
2.3	Problem description - speed variations	17
2.4	System block "LS_DigitalFrequencyInput"	18
2.5	System block "LS_TouchProbeDFIN"	20
3	Digital frequency output	21
3.1	Terminal assignment X10	21
3.2	Parameter setting	22
3.2.1	Signal source selection	23
3.2.2	Number of increments and zero pulse offset	24
3.2.3	Position setting	25
3.2.4	Use of machine parameters for scaling	26
3.2.5	Frequency limitation	27
3.2.6	Touch probe	27
3.3	Problem description - speed variations	28
3.4	System block "LS_DigitalFrequencyOutput"	29
3.5	System block "LS_TouchProbeDFOUT"	31
4	Parameter reference	32
4.1	Parameter list	32
4.2	Table of attributes	45

5	Fault messages	48
6	Index	51
	<i>Your opinion is important to us.....</i>	53

1 About this documentation

This documentation contains information on how to parameterise & configure the digital frequency extension module with the L-force »Engineer« and keypad.



Note!

This documentation completes the Mounting Instructions supplied with the extension module. It is valid only in conjunction with the respective Operating Instructions for the standard devices permitted for use.

The Mounting Instructions contain safety instructions which must be observed!

The information given in this documentation applies to:



Extension module	Type designation	From hardware version	From software version
Digital frequency	E94AYFLF	VA	-

This extension module can be used in conjunction with the following standard devices:

Product series	Type designation	From hardware version	From software version
9400 Servo Drives	E94AxxExxxx	VA	01.37

1.1 Conventions used

This documentation uses the following conventions to distinguish between different types of information:

Type of information	Writing	Examples/notes
Numbers		
Decimal separator	Point	The decimal point is always used. Example: 1234.56
Text		
Program name	» «	The Lenze PC software »Engineer«...
Window pane	<i>Italics</i>	The <i>Message window</i> ... / The <i>Options</i> dialog box...
Control element	Bold	The OK button... / The Copy command... / The Properties tab... / The Name input field...
Sequence of menu commands		If the execution of a function requires several commands, the individual commands are separated by an arrow: Select File → Open to...
Keyboard command	< Bold >	Use < F1 > to open the Online Help. If a command requires a combination of keys, a "+" is placed between the key symbols: Use < Shift >+< ESC > to...
Program listings	Courier	<pre>IF var1 < var2 THEN a = a + 1 END IF</pre>
Keyword	Courier bold	
Hyperlink	<u>Underlined</u>	Optically highlighted reference to another topic. It is activated with a mouse click in this online documentation.
Symbols		
Page reference	 6	Optically highlighted reference to another page. It is activated with a mouse click in this online documentation.
Step-by-step instructions		Step-by-step instructions are indicated by a pictograph.

1.2 Terminology used

Term	Meaning
»Engineer«	Lenze software which supports you throughout the whole machine life cycle - from planning to maintenance.
Code	"Container" for one or several parameters used for controller parameter setting or monitoring.
Subcode	If a code contains several parameters, the individual parameters are stored under "subcodes". This Manual uses a slash "/" as a separator between code and subcode (e.g. "C00118/3").
Function block	A function block (FB) can be compared with an integrated circuit that contains a certain control logic and delivers one or several values when being executed. <ul style="list-style-type: none"> • An instance (reproduction, copy) of the function block is always inserted in the circuit. • It is also possible to insert several instances of a function block in a circuit. • Each instance has a unique identifier (the instance name) and a processing number which defines the position at which the function block is calculated during the task cycle.
System block	System blocks provide interfaces to basic functions and hardware of the controller in the function block editor of the »Engineer« (e.g. to the digital inputs). <ul style="list-style-type: none"> • System blocks cannot be instanced in contrast to function blocks.

1.3 Definition of notes used

The following signal words and symbols are used in this documentation to indicate dangers and important information:

Safety instructions

Layout of the safety instructions:



Danger!

(characterises the type and severity of danger)

Note

(describes the danger and gives information about how to prevent dangerous situations)

Pictograph	Signal word	Meaning
	Danger!	Danger of personal injury through dangerous electrical voltage Indicates an impending danger that may lead to death or severe personal injury if the corresponding measures are not taken.
	Danger!	Danger of personal injury through a general source of danger Indicates an impending danger that may lead to death or severe personal injury if the corresponding measures are not taken.
	Stop!	Danger of material damage Indicates a potential danger that may lead to material damage if the corresponding measures are not taken.

Application notes

Pictograph	Signal word	Meaning
	Note!	Important note for trouble-free operation
	Tip!	Useful tip for easy handling
		Reference to another document

2 Digital frequency input

The optionally available digital frequency extension module serves to extend the L-force 9400 Servo Drive by a digital frequency input and a digital frequency output.

- ▶ The digital frequency input X9 reads encoder signals with TTL level (0 ... 500 kHz) and converts these to scaled speed and position values for the application.

2.1 Terminal assignment X9

Pin	Signal
1	B
2	\bar{A}
3	A
4	+5 V encoder voltage (controlled)
5	GND
6	\bar{Z}
7	Z
8	Sense / Lamp control / Enable
9	\bar{B}



Stop!

If an encoder is connected to X9 and supplied by the digital frequency extension module "in a controlled way", the pin 8 of the digital frequency input X9 serves to control and monitor the +5 V encoder voltage. ▶ [Monitoring](#)

In this case, no digital signal ("Lamp control" or "Enable") may be supplied to PIN 8!

Please also observe the documentation for the encoder used.

2.2 Parameter setting



Note!

Depending on the module receptacle the digital frequency extension module is plugged in, different code ranges are assigned to the parameters!

- Module receptacle MXI1: Parameters are in the C130xx range
- Module receptacle MXI2: Parameters are in the C140xx range

Short overview of the parameters for the digital frequency input:

Parameter		Info	Lenze setting	
^A	^B		Value	Unit
C13010	C14010	Encoder type DFIN	Digital frequency output DFOUT	
C13011	C14011	No. of increments DFIN	2048	
C13012	C14012	Signal form DFIN	4x evaluation (A, B)	
C13013	C14013	Initialisation time DFIN	3000	ms
C13014	C14014	Track monitoring DFIN	Active after initialisation time	
C13021	C14021	TP delay time DFIN	0	µs
C13030	C14030	Speed at DFIN	-	Incr./ms
C13031	C14031	Frequency at DFIN	-	Hz
C13032	C14032	Position at DFIN	-	Increments
C13040	C14040	Resp. to track monitoring DFIN	Warning	
C13041	C14041	No resp. to DFIN enable signal	Warning	
C13042	C14042	Resp. to Vcc error DFIN	Warning	

^A Digital frequency extension module in module receptacle MXI1
^B Digital frequency extension module in module receptacle MXI2
 Greyed out = display parameter

2.2.1 Signal form configuration

In order that the input signals are interpreted correctly from the digital frequency extension module, the setting in [C13012](#) / [C14012](#) must correspond to the signal form of the input signals applied:

4x evaluation (A, B)

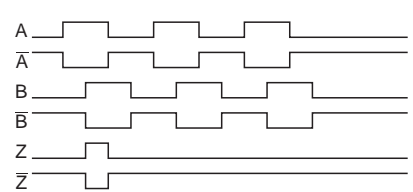
Setting C13012 / C14012 = "0"			
 <p>Phase-displaced signal sequence (CW rotation)</p>		CW rotation	CCW rotation
	Track A	leads track B by 90°	lags track B by 90°
	Track B	-	-

A:Increments B:Sign

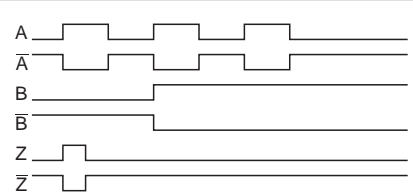
Setting C13012 / C14012 = "1"			
 <p>Control of the direction of rotation via track B</p>		CW rotation	CCW rotation
	Track A	transmits the speed	transmits the speed
	Track B	= FALSE	= TRUE

Increments A:pos. B:neg.

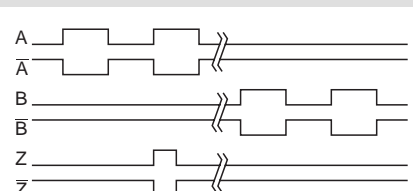
Setting C13012 / C14012 = "2"			
 <p>Control of speed and direction of rotation via track A or track B</p>		CW rotation	CCW rotation
	Track A	transmits speed and direction of rotation	= FALSE
	Track B	= FALSE	transmits speed and direction of rotation

2.2.2 Encoder signal detection

From the encoder signals applied to digital frequency input X9 and the number of increments set in [C13011](#) / [C14011](#) the speed is created in [rpm] and provided to the application via the output *DFIN_nActualSpeed_s* of the system block **LS_DigitalFrequencyInput**.

At the same time the detected speed is integrated to a 32-bit absolute position and provided to the application via the output *DFIN_dnActualPos_p* of the system block **LS_DigitalFrequencyInput**.

See also: [▶ Problem description - speed variations \(□ 17\)](#)

2.2.3 Position setting

The 32-bit absolute position output by the system block **LS_DigitalFrequencyInput** at the output *DFIN_dnActualPos_p* can be set as follows to a certain position value:

1. Define the desired absolute position at the input *DFIN_dnReferencePos_p* in [increments].
2. Set the input *DFIN_bLoadReferencePos* from FALSE to TRUE to accept the defined position for the digital frequency input in the next cycle.



Note!

The speed is not affected by setting the position.

If the speed is integrated in the application, the integrator and the position assume different values, i.e. they diverge. In case of further position changes, the difference between the values remains the same.

2.2.4 Use of machine parameters for scaling

This function extension is available from software version V3.0 onwards!

The input *DFIN_AxisData* can be used to transfer the machine parameters of the own motor/drive or of a higher-level drive to the system block **LS_DigitalFrequencyInput**.

- ▶ If valid machine parameters are applied to the input *DFIN_AxisData*, then the outputs for the actual position and the actual speed are evaluated on the basis of the transferred machine parameters (gearbox factors, encoder resolution).
 - The position is scaled to the set measuring system/traversing range.
 - The encoder mounting position can be parameterised under [C13015](#) / [C14015](#).
- ▶ If the input *DFIN_AxisData* remains unused, the system block continues to operate as before. In this case the units are scaled to revolutions.



Tip!

With this function extension, the system block **LS_DigitalFrequencyInput** can be coupled directly to a master value measuring system. The system block then uses the units of this measuring system for processing.

Short overview of the parameters for this function extension:

Parameter		Info	Lenze setting	
A	B		Value	Unit
C13015	C14015	Encoder mounting position DFIN	Clockwise rotation	
C13035/1	C14035/1	Position unit DFIN	-	
C13035/2	C14035/2	Speed unit DFIN	-	
C13036	C14036	Actual position DFIN	-	Unit
C13037	C14037	Actual speed DFIN	-	Unit/t

A Digital frequency extension module in module receptacle MXI1
B Digital frequency extension module in module receptacle MXI2
 Greyed out = display parameter

2.2.5 Voltage control - TTL encoder

If a TTL encoder is connected as the signal source and [C13010](#) / [C14010](#) is set to TTL encoder, the encoder can be supplied with a controlled +5 V voltage via pin 4, which serves to compensate the voltage drop on the encoder cable.



Stop!

If an encoder is connected to X9 and supplied by the digital frequency extension module "in a controlled way", the pin 8 of the digital frequency input X9 serves to control and monitor the +5 V encoder voltage. ▶ [Monitoring](#)

In this case, no digital signal ("Lamp control" or "Enable") may be supplied to PIN 8!

Please also observe the documentation for the encoder used.

2.2.6 Monitoring

Initialisation time

In [C13013](#) / [C14013](#) an initialisation time can be set, which must elapse after starting the system before the monitoring modes are switched active.

- ▶ Thanks to this "delay" other system parts which serve as signal sources, can initialise themselves first without monitoring being triggered due to missing signals.
- ▶ In the "0" setting the initialisation time is set to infinity so that monitoring is deactivated permanently.
- ▶ If the setting is changed from "0" to another value, the initialisation time is restarted.
 - A higher-level control can, for instance, switch monitoring active by a corresponding parameter setting of [C13013](#) / [C14013](#) even if the device has been switched on for a long time.

Monitoring of the +5 V voltage for the encoder

If an encoder is connected to X9 and supplied by the digital frequency extension module "in a controlled way", the pin 8 of the digital frequency input X9 serves to control and monitor the +5 V encoder voltage.

- ▶ If the voltage control is not able to compensate the voltage drop, a fault message is created and the response set in [C13042](#) / [C14042](#) is executed.
 - At the same time the output *DFIN_bVccCtrlLimited* of the system block **LS_DigitalFrequencyInput** is set to TRUE.

Monitoring of the "Enable" or "Lamp control" signal

If the +5 V encoder voltage is not controlled by the digital frequency extension module, a digital signal can be read in and monitored via pin 8 of the digital frequency input X9, e.g. the "Lamp control" signal of an encoder or the "Enable" signal of an upstream digital frequency module.

- ▶ If pin 8 of the digital frequency input X9 is not set to HIGH level (+5V) after the initialisation time has elapsed, a fault message is generated and the response set in [C13041](#) / [C14041](#) is executed.
- ▶ The binary status of pin 8 is also displayed at the output *DFIN_bSense* of the system block **LS_DigitalFrequencyInput**.

Track monitoring (open circuit detection)

The signal tracks A, B, and Z are monitored with regard to their differential voltage value.

- ▶ For the activation of track monitoring, two modes are available in [C13014](#) / [C14014](#):

C13014 / C14014 = "1"	C13014 / C14014 = "2"
The track monitoring modes are activated after the initialisation time has elapsed. <ul style="list-style-type: none"> • The initialisation time is set in C13013 / C14013. 	The track monitoring modes only become active if pin 8 of the digital frequency input X9 is set to HIGH level (+5 V). <ul style="list-style-type: none"> • They may be activated e.g. by an encoder (status "Lamp control") or an upstream digital frequency module (status "Enable"). • When this mode is selected, monitoring can be switched active by a signal source if the levels on the tracks have valid values.

- ▶ Monitoring is both done at standstill and while the encoder is rotating.
- ▶ If track monitoring responds, a fault message is generated and the response set in [C13040](#) / [C14040](#) is executed.
 - At the same time the corresponding output *DFIN_bTrackAError*, *DFIN_bTrackBError* or *DFIN_bTrackZError* of the system block **LS_DigitalFrequencyInput** is set to TRUE.

2.2.7 Touch probe

When the zero pulse occurs on track Z - \bar{Z} , a touch probe is triggered.

- ▶ The corresponding signals to execute touch probe processing are available via the system block **LS_TouchProbeDFIN**.
- ▶ In [C13021](#) / [C14021](#) a delay time can be set for the touch probe.
- ▶ If a touch probe has been triggered, the output *DFIN_bTouchProbeReceived* is set to TRUE for one cycle.



Tip!

Detailed information on touch probe processing can be found in the online documentation for the controller in chapter "I/O terminals→Touch probe detection".

2.3 Problem description - speed variations

In the digital frequency extension module rectangular encoder signals are processed. The speed is determined by counting the edges occurring within a defined time interval (1 ms). Due to this defined time interval of 1 ms and a finite number of encoder increments per revolution, the calculated speed signal can only assume discrete values. This gives the impression that the signal is very unsteady and inexact. This effect increases with lower numbers of increments.

An example for calculating the expected speed variation can be found in chapter "Digital frequency output". ▶ [Problem description - speed variations](#) (📖 28)

Digital frequency extension module | Parameter setting & configuration

Digital frequency input

System block "LS_DigitalFrequencyInput"

2.4 System block "LS_DigitalFrequencyInput"

The system block **LS_DigitalFrequencyInput** displays the optional digital frequency extension module in the FB editor of the »Engineer«.

- ▶ The system block must be called cyclically since only then speed and position will be calculated accurately to increments.

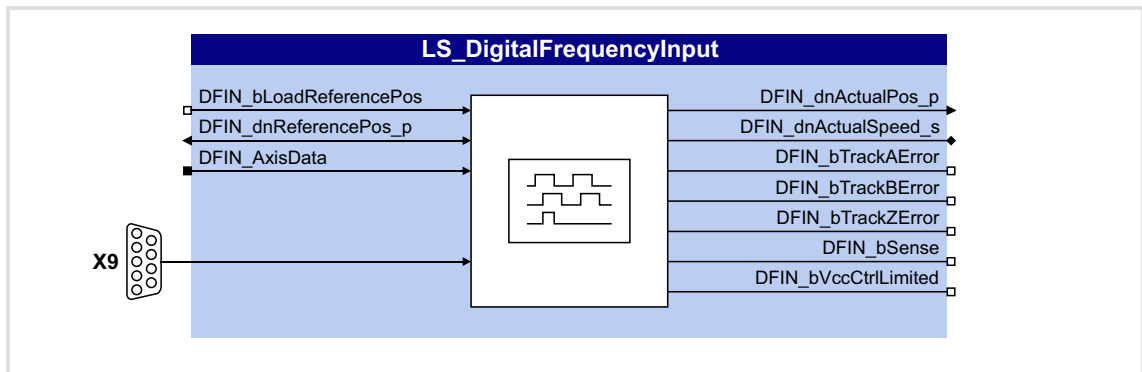

Inputs

Input	Data type	Info/possible settings
DFIN_bLoadReferencePos	BOOL	Position setting ▶ Position setting (12)
		FALSE↗TRUE Sets the 32-bit absolute position output at the output <i>DFIN_dnActualPos_p</i> to the value which is applied to input <i>DFIN_dnReferencePos_p</i> .
DFIN_dnReferencePos_p	DINT	Absolute position in [increments], to which the output <i>DFIN_dnActualPos_p</i> is set by a FALSE-TRUE edge at input <i>DFIN_bLoadReferencePos</i> . ▶ Position setting (12)
DFIN_AxisData	V3.0 or higher	Machine parameters <ul style="list-style-type: none"> • To transfer the machine parameters of the drive/motor, connect this input to the output <i>DI_AxisData</i> of SB LS_DriveInterface. • The machine parameters of a higher-level drive can be transferred via the FB L_SdSetAxisData. For this purpose, you have to connect the FB's <i>AxisData</i> output to this input. • If the input remains unused, the system block continues to operate as before. In this case the units are scaled to revolutions. ▶ Use of machine parameters for scaling (13)

Outputs

Output	Data type	Value/meaning		
DFIN_dnActualPos_p	DINT	<p>Current position in [increments]</p> <ul style="list-style-type: none"> Output as signed 32-bit value (positive value \equiv CW rotation). <p>For software versions prior to V3.0:</p> <ul style="list-style-type: none"> A virtual revolution is resolved to 16 bits. <p>For software version V3.0 or higher:</p> <ul style="list-style-type: none"> If valid machine parameters are applied to the input <i>DFIN_AxisData</i>, a virtual revolution is resolved with the encoder resolution specified in the machine parameters. If the input <i>DFIN_AxisData</i> remains unused, a virtual revolution is resolved with the setting under C00100 (Lenze setting: 16 bits). 		
DFIN_dnActualSpeed_s	DINT	<p>Current speed in [rpm]</p> <p>▶ Problem description - speed variations (📖 17)</p>		
DFIN_bTrackAError	BOOL	<p>Status signal "Differential signal of track A - \bar{A} invalid"</p> <p>▶ Monitoring (📖 14)</p> <table border="1"> <tr> <td>TRUE</td> <td>The differential signal of track A - \bar{A} is outside the valid voltage range (open circuit).</td> </tr> </table>	TRUE	The differential signal of track A - \bar{A} is outside the valid voltage range (open circuit).
TRUE	The differential signal of track A - \bar{A} is outside the valid voltage range (open circuit).			
DFIN_bTrackBError	BOOL	<p>Status signal "Differential signal of track B - \bar{B} invalid"</p> <p>▶ Monitoring (📖 14)</p> <table border="1"> <tr> <td>TRUE</td> <td>The differential signal of track B - \bar{B} is outside the valid voltage range (open circuit).</td> </tr> </table>	TRUE	The differential signal of track B - \bar{B} is outside the valid voltage range (open circuit).
TRUE	The differential signal of track B - \bar{B} is outside the valid voltage range (open circuit).			
DFIN_bTrackZError	BOOL	<p>Status signal "Differential signal of track Z - \bar{Z} invalid"</p> <p>▶ Monitoring (📖 14)</p> <table border="1"> <tr> <td>TRUE</td> <td>The differential signal of track Z - \bar{Z} is outside the valid voltage range (open circuit).</td> </tr> </table>	TRUE	The differential signal of track Z - \bar{Z} is outside the valid voltage range (open circuit).
TRUE	The differential signal of track Z - \bar{Z} is outside the valid voltage range (open circuit).			
DFIN_bSense	BOOL	<p>Status signal "Enable/Lamp control signal is set"</p> <p>▶ Monitoring (📖 14)</p> <table border="1"> <tr> <td>TRUE</td> <td>An upstream digital frequency output has set the "Enable signal" (HIGH signal at X9, pin 8).</td> </tr> </table>	TRUE	An upstream digital frequency output has set the "Enable signal" (HIGH signal at X9, pin 8).
TRUE	An upstream digital frequency output has set the "Enable signal" (HIGH signal at X9, pin 8).			
DFIN_bVccCtrlLimited	BOOL	<p>Status signal "Voltage control for TTL encoder is at the limit"</p> <p>▶ Voltage control - TTL encoder (📖 14)</p> <table border="1"> <tr> <td>TRUE</td> <td>The voltage control for a connected TTL encoder has reached the limit value.</td> </tr> </table>	TRUE	The voltage control for a connected TTL encoder has reached the limit value.
TRUE	The voltage control for a connected TTL encoder has reached the limit value.			

2.5 System block "LS_TouchProbeDFIN"

The system block **LS_TouchProbeDFIN** provides the touch probe signals of the digital frequency input of the optional digital frequency extension module in the FB editor of the »Engineer«.

- ▶ The touch probe is triggered when a zero pulse occurs on track Z - \bar{Z} .
- ▶ In [C13021](#) / [C14021](#) a delay time can be set for the touch probe.
- ▶ When a touch probe has been triggered, the output *DFIN_bTouchProbeReceived* is set to TRUE for one cycle of the task in which the SB is being processed.

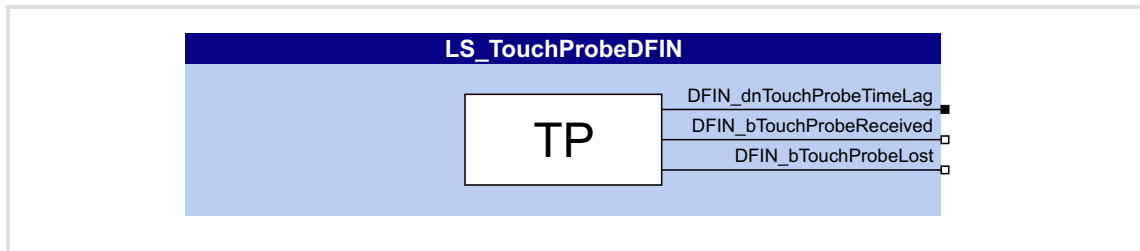

Outputs

Output	Data type	Value/meaning
DFIN_dnTouchProbeTimeLag	DINT	Scaled time stamp for further processing of the touch probe event with the FB L_SdTouchProbe .
DFIN_bTouchProbeReceived	BOOL	Status signal "Touch probe detected" <ul style="list-style-type: none"> • Status is only pending for one cycle of the task in which the SB is being processed.
		TRUE Touch probe event has been triggered.
DFIN_bTouchProbeLost	BOOL	Status signal "Touch probe(s) lost" <ul style="list-style-type: none"> • Status is only pending for one cycle of the task in which the SB is being processed.
		TRUE More than one touch probe event has been triggered within the task runtime and could therefore not be registered anymore.



Tip!

Detailed information on touch probe processing can be found in the online documentation for the controller in chapter "I/O terminals→Touch probe detection".

3 Digital frequency output

The optionally available digital frequency extension module serves to extend the L-force 9400 Servo Drive by a digital frequency input and a digital frequency output.

- ▶ The digital frequency output X10 serves to output encoder signals with TTL level (0 ... 500 kHz).

3.1 Terminal assignment X10

Pin	Signal
1	B
2	\bar{A}
3	A
4	+5 V ($\pm 6\%$)
5	GND
6	\bar{Z}
7	Z
8	Enable
9	\bar{B}

3.2 Parameter setting



Note!

Depending on the module receptacle the digital frequency extension module is plugged in, different code ranges are assigned to the parameters!

- Module receptacle MXI1: Parameters are in the C130xx range
- Module receptacle MXI2: Parameters are in the C140xx range

Short overview of the parameters for the digital frequency output:

Parameter		Info	Lenze setting	
^A	^B		Value	Unit
C13050	C14050	Signal source DFOUT	Application	
C13051	C14051	No. of increments DFOUT	2048	
C13052	C14052	Zero pulse offset DFOUT	0	Increments
C13053	C14053	Frequency limitation DFOUT	500	kHz
C13061	C14061	TP delay time DFOUT	0	µs
C13070	C14070	Speed at DFOUT	-	Incr./ms
C13071	C14071	Frequency at DFOUT	-	Hz
C13072	C14072	Position at DFOUT	-	Increments
C13080	C14080	Resp. to frequency limit. DFOUT	Warning	

^A Digital frequency extension module in module receptacle MXI1
^B Digital frequency extension module in module receptacle MXI2
 Greyed out = display parameter

3.2.1 Signal source selection

The signal source for the digital frequency output is selected in [C13050](#) / [C14050](#):

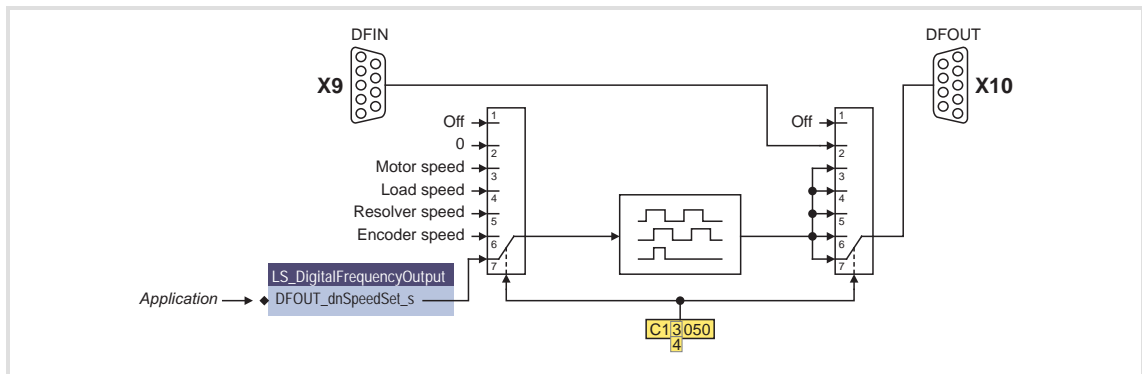

[3-1] Selection of the signal source for X10

Selection	Info
1	Digital frequency output is inactive <ul style="list-style-type: none"> • "0" frequency is output a the digital frequency output. • All tracks remain on the level output last. • After the controller is switched on, the tracks A, B, and Z are set to HIGH level.
2	The digital frequency input X9 is directly connected to the digital frequency output. <p>Note:</p> Due to the direct connection between input and output, sensors are no longer required. <ul style="list-style-type: none"> • The zero pulse offset (C13052 / C14052) is without function. • The frequency limitation (C13053 / C14053) is without function. • The zero track is only output if connected to X9. • The display parameters for the actual values (speed, frequency, position) are not updated (remedy: use display parameters of the digital frequency input). • The outputs <i>DFOUT_dnActualPos_p</i> and <i>DFOUT_dnActualSpeed_s</i> of the system block LS_DigitalFrequencyOutput are not updated.
3	Output of the motor encoder <ul style="list-style-type: none"> • The angle of rotation in [increments] derived from the motor encoder is output as a frequency signal after being evaluated with the set number of increments (C13051 / C14051). • The output signal is integrated to a position value via a counter and made available to the application via the output <i>DFOUT_dnActualPos_p</i> of the system block LS_DigitalFrequencyOutput.
4	Output of the load encoder <ul style="list-style-type: none"> • The angle of rotation in [increments] derived from the load encoder is output as a frequency signal after being evaluated with the set number of increments (C13051 / C14051). • The output signal is integrated to a position value via a counter and made available to the application via the output <i>DFOUT_dnActualPos_p</i> of the system block LS_DigitalFrequencyOutput.
5	Output of the resolver angle <ul style="list-style-type: none"> • The angle of rotation in [increments] derived from the resolver input is output as a frequency signal after being evaluated with the set number of increments (C13051 / C14051). • The output signal is integrated to a position value via a counter and made available to the application via the output <i>DFOUT_dnActualPos_p</i> of the system block LS_DigitalFrequencyOutput. • It is irrelevant for the output whether the resolver input is used as a load encoder, motor encoder, or not used at all for the motor control.

Selection	Info
6	<p>Output of the encoder angle</p> <ul style="list-style-type: none"> The angle of rotation in [increments] derived from the encoder input is output as a frequency signal after being evaluated with the set number of increments (C13051 / C14051). The output signal is integrated to a position value via a counter and made available to the application via the output <i>DFOUT_dnActualPos_p</i> of the system block LS_DigitalFrequencyOutput. It is irrelevant for the output whether the encoder input is used as a load encoder, motor encoder, or not used at all for the motor control.
7	<p>Output of a speed signal of the application</p> <ul style="list-style-type: none"> The speed signal in [rpm] defined via the input <i>DFOUT_dnSpeedSet_s</i> of the system block LS_DigitalFrequencyOutput is integrated and output as a frequency signal after being evaluated with the set number of increments (C13051 / C14051). The output signal is integrated to a position value via a counter and made available to the application via the output <i>DFOUT_dnActualPos_p</i> of the system block LS_DigitalFrequencyOutput.

3.2.2 Number of increments and zero pulse offset

The number of increments set in [C13051](#) / [C14051](#) defines e.g. the number of increment to be output before a zero pulse is created.

- ▶ Each zero pulse defines a covered "revolution" of the rotary transducer simulated by the digital frequency output.
- ▶ Within such a "revolution" (in the value range 0 ... 65535 increments) the zero pulse can be shifted by setting a zero pulse offset in [C13052](#) / [C14052](#).

A connection between absolute position and "revolution" is defined by setting the position, as described in the following chapter "[Position setting](#)". The position of a zero pulse within a "revolution" remains unchanged.

Example - signal characteristic:

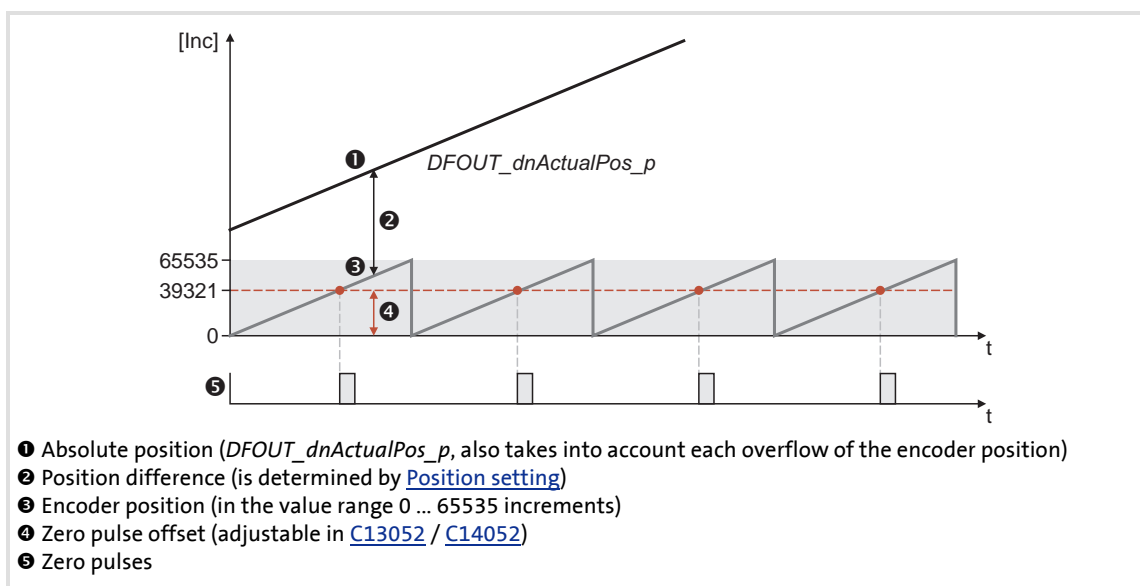

[3-2] Example: Signal characteristic with the zero pulse offset set to 39321 increments

3.2.3 Position setting

The digital frequency output provides a 32-bit absolute position for the application via the output *DFOUT_dnActualPos_p*. This absolute position is created by integrating the frequency signal to be output.

This position can be set as follows via the system block **LS_DigitalFrequencyOutput** :

1. Define the desired absolute position at the input *DFOUT_dnReferencePos_p* in [increments].
2. Set the input *DFOUT_bLoadReferencePos* from FALSE to TRUE to accept the defined position for the digital frequency output in the next cycle.



Note!

The speed is not affected by setting the position.

If the speed is integrated in the application, the integrator and the position assume different values, i.e. they diverge. In case of further position changes, the difference between the values remains the same.

3.2.4 Use of machine parameters for scaling

This function extension is available from software version V3.0 onwards!

The input *DFOUT_AxisData* can be used to transfer the machine parameters of the own motor/drive or of a higher-level drive to the system block **LS_DigitalFrequencyOutput**.

- ▶ If valid machine parameters are applied to the input *DFOUT_AxisData*, then the outputs for the actual position and the actual speed are evaluated on the basis of the transferred machine parameters (gearbox factors, encoder resolution) and the position is scaled to the set measuring system/traversing range.
- ▶ If the input *DFOUT_AxisData* remains unused, the system block continues to operate as before. In this case the units are scaled to revolutions.



Tip!

With this function extension, the system block **LS_DigitalFrequencyOutput** can be coupled directly to a master value measuring system. The system block then uses the units of this measuring system for processing.

Short overview of the parameters for this function extension:

Parameter		Info	Lenze setting	
A	B		Value	Unit
C13075/1	C14075/1	Position unit DFOUT	-	
C13075/2	C14075/2	Speed unit DFOUT	-	
C13076	C14076	Actual position DFOUT	-	Unit
C13077	C14077	Actual speed DFOUT	-	Unit/t

A Digital frequency extension module in module receptacle MXI1
B Digital frequency extension module in module receptacle MXI2
 Greyed out = display parameter

3.2.5 Frequency limitation

In [C13053](#) / [C14053](#) a frequency limitation can be set for the digital frequency output.

- ▶ If the frequency is limited, a fault message is generated and the response set in [C13080](#) / [C14080](#) is executed.
 - At the same time the output *DFOUT_bOutputFreqLimited* of the system block **LS_DigitalFrequencyOutput** is set to TRUE.
- ▶ The hardware limits the digital frequency output to 500 kHz.



Note!

- Due to the remainder processing implemented in the 4 kHz control cycle, only settings ≥ 4 kHz are reasonable for frequency limitation!
- If the digital frequency input is directly connected to the digital frequency output, the set frequency limitation is without function!

3.2.6 Touch probe

When the zero pulse occurs on track $Z - \bar{Z}$, a touch probe is triggered.

- ▶ The corresponding signals to execute touch probe processing are available via the system block **LS_TouchProbeDFOUT**.
- ▶ In [C13061](#) / [C14061](#) a delay time can be set for the touch probe.
- ▶ If a touch probe has been triggered, the output *DFOUT_bTouchProbeReceived* is set to TRUE for one cycle.



Tip!

Detailed information on touch probe processing can be found in the online documentation for the controller in chapter "I/O terminals→Touch probe detection".

3.3 Problem description - speed variations

In the digital frequency extension module rectangular encoder signals are processed. The speed is determined by counting the edges occurring within a defined time interval (1 ms). Due to this defined time interval of 1 ms and a finite number of encoder increments per revolution, the calculated speed signal can only assume discrete values. This gives the impression that the signal is very unsteady and inexact. This effect increases with lower numbers of increments.

Example for the digital frequency output

An encoder with 2048 increments at a speed of 60 rpm is to be simulated.

- ▶ Setpoint speed $n_{\text{set_DFOUT}} = 60 \text{ rpm} = 1 \text{ Hz}_{\text{mech.}}$
- ▶ Simulated encoder: 2048 increments
(by fourfold evaluation $4 * 2048 = 8192$ edges are counted per revolution)
- ▶ Output frequency = $n_{\text{set_DFOUT}} * \text{number of increments}_{\text{DFOUT}} = 1 \text{ Hz}_{\text{mech.}} * 2048 = 2048 \text{ Hz}$

If the measurement lasts 1 ms, 8.192 edges occur per ms. Since the count can only be an integer, 8 or 9 increments are counted. Thus, the speed is calculated as follows:

$$n_{\text{measure}_1} = 60 \text{ rpm} \cdot \frac{8}{8.192} = 58.59 \text{ rpm}$$

or

$$n_{\text{measure}_2} = 60 \text{ rpm} \cdot \frac{9}{8.192} = 65.91 \text{ rpm}$$

The speed variation which is detected during this process amounts to:

$$\Delta n_{\text{measure}} = n_{\text{measure}_2} - n_{\text{measure}_1} = 7.32 \text{ rpm}$$

General formula for calculating the expected speed variation

$$\Delta n_{\text{measure}} = \frac{15000}{\text{number of increments}} \text{ rpm}$$

3.4 System block "LS_DigitalFrequencyOutput"

The system block **LS_DigitalFrequencyOutput** displays the digital frequency output of the optional extension module in the FB editor of the »Engineer«:

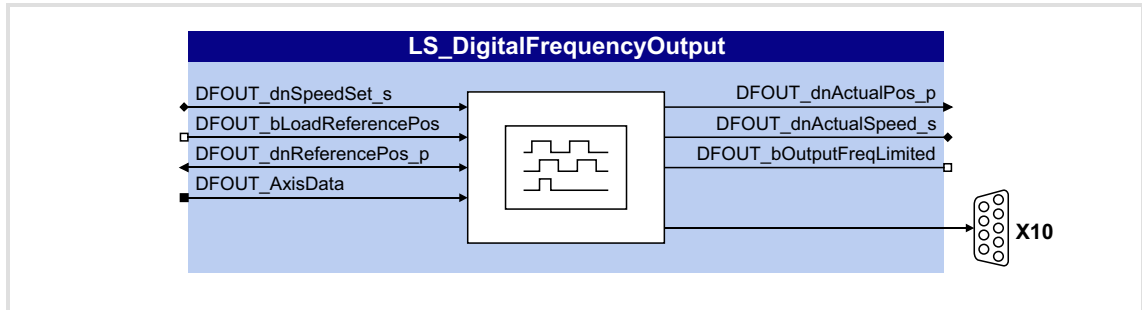

Inputs

Input	Data type	Info/possible settings
DFOUT_dnSpeedSet_s	DINT	Speed in [rpm], which is to be output via the digital frequency output as encoder signals with TTL level. <ul style="list-style-type: none"> To select this signal source, C13050 / C14050 = "7" must be set. ▶ Signal source selection (23)
DFOUT_bLoadReferencePos	BOOL	Position setting <ul style="list-style-type: none"> ▶ Position setting (25) FALSE↗TRUE Sets the 32-bit absolute position output at the output <i>DFOUT_dnActualPos_p</i> to the value which is applied to input <i>DFOUT_dnReferencePos_p</i> .
DFOUT_dnReferencePos_p	DINT	Absolute position in [increments], to which the output <i>DFOUT_dnActualPos_p</i> is set by a FALSE-TRUE edge at input <i>DFOUT_bLoadReferencePos</i> . <ul style="list-style-type: none"> ▶ Position setting (25)
DFOUT_AxisData	V3.0 or higher	Machine parameters <ul style="list-style-type: none"> To transfer the machine parameters of the drive/motor, connect this input to the output <i>DI_AxisData</i> of SB LS_DriveInterface. The machine parameters of a higher-level drive can be transferred via the FB L_SdSetAxisData. For this purpose, you have to connect the FB's <i>AxisData</i> output to this input. If the input remains unused, the system block continues to operate as before. In this case the units are scaled to revolutions. ▶ Use of machine parameters for scaling (26)

Digital frequency extension module | Parameter setting & configuration

Digital frequency output

System block "LS_DigitalFrequencyOutput"

Outputs

Output	Data type	Value/meaning
DFOUT_dnActualPos_p	DINT	Current position as signed 32-bit value in [increments] For software versions prior to V3.0: • A virtual revolution is resolved to 16 bits. For software version V3.0 or higher: • If valid machine parameters are applied to the input <i>DFOUT_AxisData</i> , a virtual revolution is resolved with the encoder resolution specified in the machine parameters. • If the input <i>DFOUT_AxisData</i> remains unused, a virtual revolution is resolved with the setting under C00100 (Lenze setting: 16 bits).
DFOUT_dnActualSpeed_s	DINT	Current speed in [rpm] ▶ Problem description - speed variations (📖 28)
DFOUT_bOutputFreqLimited	BOOL	Status signal "Frequency to be output is limited" ▶ Frequency limitation (📖 27)
		TRUE The frequency to be output is limited by the value set in C13053 / C14053 .

3.5 System block "LS_TouchProbeDFOUT"

The system block **LS_TouchProbeDFOUT** provides the touch probe signals of the digital frequency output of the optional digital frequency extension module in the FB editor of the »Engineer«.

- ▶ The touch probe is triggered when a zero pulse occurs on track $Z - \bar{Z}$.
- ▶ In [C13061](#) / [C14061](#) a delay time can be set for the touch probe.
- ▶ When a touch probe has been triggered, the output *DFOUT_bTouchProbeReceived* is set to TRUE for one cycle of the task in which the SB is being processed.

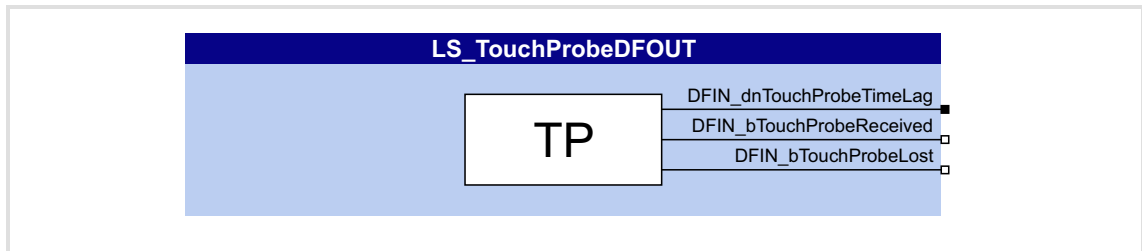

Outputs

Output	Data type	Value/meaning
DFIN_dnTouchProbeTimeLag	DINT	Scaled time stamp for further processing of the touch probe event with the FB L_SdTouchProbe .
DFOUT_bTouchProbeReceived	BOOL	Status signal "Touch probe detected" <ul style="list-style-type: none"> • Status is only pending for one cycle of the task in which the SB is being processed.
		TRUE Touch probe event has been triggered.
DFOUT_bTouchProbeLost	BOOL	Status signal "Touch probe(s) lost" <ul style="list-style-type: none"> • Status is only pending for one cycle of the task in which the SB is being processed.
		TRUE More than one touch probe event has been triggered within the task runtime and could therefore not be registered anymore.



Tip!

Detailed information on touch probe processing can be found in the online documentation for the controller in chapter "I/O terminals→Touch probe detection".

4 Parameter reference



Note!

This chapter completes the parameter list and attribute table in the online documentation for the controller by parameters of the digital frequency extension module.



Tip!

General information on parameters can be found in the online documentation for the controller.

4.1 Parameter list

This chapter contains all parameters of the digital frequency extension module in numerically ascending order.

Abbreviated units

Abbreviation	Meaning
Incr.	Increments

C13010

Parameter | Name: **C13010 | Encoder type DFIN** Data type: UNSIGNED_8
Index: 11565_d = 2D2D_h

Digital frequency extension module in module receptacle MXI1:
Selection of the encoder type for digital frequency input X9

Selection list (Lenze setting in bold)

1	Digital frequency output DFOUT
2	TTL encoder

Read access Write access CINH PLC-STOP No transfer

C13011

Parameter | Name: **C13011 | No. of increments DFIN** Data type: UNSIGNED_32
Index: 11564_d = 2D2C_h

Digital frequency extension module in module receptacle MXI1:
Number of increments for digital frequency input X9
• Definition of the number of pulses for one "mechanical" revolution.

Setting range (min. value | unit | max. value) **Lenze setting**

1		16384	2048
---	--	-------	-------------

Read access Write access CINH PLC-STOP No transfer

C13012

Parameter | Name: **C13012 | Signal format DFIN** Data type: UNSIGNED_8
Index: 11563_d = 2D2B_h

Digital frequency extension module in module receptacle MXI1:
Signal form for digital frequency input X9
• Selection of how to interpret the input signal.

Selection list (Lenze setting in bold)

0	4x evaluation (A, B)
1	A:Increments B:Sign
2	Increments A:pos. B:neg.

Read access Write access CINH PLC-STOP No transfer

C13013

Parameter | Name: **C13013 | Initialisation time DFIN** Data type: UNSIGNED_16
Index: 11562_d = 2D2A_h

Digital frequency extension module in module receptacle MXI1:
Initialisation time for digital frequency input X9
• Waiting time after which the "Enable" signal is evaluated and the track monitoring modes are switched active.

Setting range (min. value | unit | max. value) **Lenze setting**

0	ms	65535	3000 ms
---	----	-------	----------------

Read access Write access CINH PLC-STOP No transfer

C13014

Parameter | Name: **C13014 | Track monitoring DFIN** Data type: UNSIGNED_8
Index: 11561_d = 2D29_h

Digital frequency extension module in module receptacle MXI1:
Monitoring configuration for digital frequency input X9
• Selection when track monitoring modes (open circuit detection) are active.

Selection list (Lenze setting in bold)

1	Active after initialisation time
2	Active after enable signal

Read access Write access CINH PLC-STOP No transfer

Digital frequency extension module | Parameter setting & configuration

Parameter reference

Parameter list | C13015

C13015

Parameter Name: C13015 Encoder mounting dir. (DFIN)		Data type: UNSIGNED_32 Index: 11560 _d = 2D28 _h
Selection list (Lenze setting in bold)		Info
0	Clockwise direction of rotation	
1	Counter-clockwise direction of rotation	
<input checked="" type="checkbox"/> Read access <input checked="" type="checkbox"/> Write access <input checked="" type="checkbox"/> CINH <input type="checkbox"/> PLC-STOP <input type="checkbox"/> No transfer		

C13021

Parameter Name: C13021 TP delay time DFIN		Data type: UNSIGNED_32 Index: 11554 _d = 2D22 _h
Digital frequency extension module in module receptacle MXI1: Touch probe delay for digital frequency input X9 • The delay time set is considered when the position at the instant of touch probe is determined (instant of zero pulse) and serves to compensate dead times, if existent.		
Setting range (min. value unit max. value)		Lenze setting
0	µs	7000 0 µs
<input checked="" type="checkbox"/> Read access <input checked="" type="checkbox"/> Write access <input type="checkbox"/> CINH <input type="checkbox"/> PLC-STOP <input type="checkbox"/> No transfer		

C13030

Parameter Name: C13030 Speed at DFIN		Data type: INTEGER_32 Index: 11545 _d = 2D19 _h
Digital frequency extension module in module receptacle MXI1: Display of the current speed at digital frequency input X9		
Display range (min. value unit max. value)		
-2147483648	Incr./ms	2147483647
<input checked="" type="checkbox"/> Read access <input type="checkbox"/> Write access <input type="checkbox"/> CINH <input type="checkbox"/> PLC-STOP <input type="checkbox"/> No transfer		

C13031

Parameter Name: C13031 Frequency at DFIN		Data type: INTEGER_32 Index: 11544 _d = 2D18 _h
Digital frequency extension module in module receptacle MXI1: Display of the current frequency at digital frequency input X9		
Display range (min. value unit max. value)		
-2147483648	Hz	2147483647
<input checked="" type="checkbox"/> Read access <input type="checkbox"/> Write access <input type="checkbox"/> CINH <input type="checkbox"/> PLC-STOP <input type="checkbox"/> No transfer		

C13032

Parameter Name: C13032 Position at DFIN		Data type: INTEGER_32 Index: 11543 _d = 2D17 _h
Digital frequency extension module in module receptacle MXI1: Display of the current position at digital frequency input X9		
Display range (min. value unit max. value)		
-2147483648	Incr.	2147483647
<input checked="" type="checkbox"/> Read access <input type="checkbox"/> Write access <input type="checkbox"/> CINH <input type="checkbox"/> PLC-STOP <input type="checkbox"/> No transfer		

C13035

Parameter Name: C13035 Unit		Data type: VISIBLE_STRING Index: 11540 _d = 2D14 _h
Subcodes		Info
C13035/1		Unit for the position
C13035/2		Unit for the speed
<input checked="" type="checkbox"/> Read access <input type="checkbox"/> Write access <input type="checkbox"/> CINH <input type="checkbox"/> PLC-STOP <input type="checkbox"/> No transfer		

C13036

Parameter Name: C13036 Actual position DFIN		Data type: INTEGER_32 Index: 11539 _d = 2D13 _h
Display range (min. value unit max. value)		
-214748.3647	Unit	214748.3647
<input checked="" type="checkbox"/> Read access <input type="checkbox"/> Write access <input type="checkbox"/> CINH <input type="checkbox"/> PLC-STOP <input type="checkbox"/> No transfer		Scaling factor: 10000

C13037

Parameter Name: C13037 Actual speed DFIN		Data type: INTEGER_32 Index: 11538 _d = 2D12 _h
Display range (min. value unit max. value)		
-214748.3647	Unit/s	214748.3647
<input checked="" type="checkbox"/> Read access <input type="checkbox"/> Write access <input type="checkbox"/> CINH <input type="checkbox"/> PLC-STOP <input type="checkbox"/> No transfer		Scaling factor: 10000

C13040

Parameter Name: C13040 Resp. to track monitoring DFIN		Data type: UNSIGNED_8 Index: 11535 _d = 2D0F _h
Digital frequency extension module in module receptacle MX11:		
Response when track monitoring is triggered for digital frequency input X9		
<ul style="list-style-type: none"> Track monitoring is triggered if a signal cable (A, B, or Z) is interrupted. 		
Selection list (Lenze setting in bold)		
1	Fault	
2	Trouble	
3	Quick stop by trouble	
5	Warning	
4	Warning locked	
6	Information	
0	No response	
<input checked="" type="checkbox"/> Read access <input checked="" type="checkbox"/> Write access <input type="checkbox"/> CINH <input type="checkbox"/> PLC-STOP <input type="checkbox"/> No transfer		

C13041

Parameter Name: C13041 Resp. to DFIN enable sig. miss.		Data type: UNSIGNED_8 Index: 11534 _d = 2D0E _h
Digital frequency extension module in module receptacle MX11:		
Response when "Enable" signal at digital frequency input X9 fails		
Selection list (Lenze setting in bold)		
1	Fault	
2	Trouble	
3	Quick stop by trouble	
5	Warning	
4	Warning locked	
6	Information	
0	No response	
<input checked="" type="checkbox"/> Read access <input checked="" type="checkbox"/> Write access <input type="checkbox"/> CINH <input type="checkbox"/> PLC-STOP <input type="checkbox"/> No transfer		

Digital frequency extension module | Parameter setting & configuration

Parameter reference

Parameter list | C13042

C13042

Parameter Name: C13042 Resp. to Vcc error DFIN	Data type: UNSIGNED_8 Index: 11533 _d = 2D0D _h
Digital frequency extension module in module receptacle MXI1: Response when monitoring for encoder voltage supply at digital frequency input X9 is triggered <ul style="list-style-type: none"> Monitoring is triggered if the encoder voltage controlled by the digital frequency input reaches the voltage limit. 	
Selection list (Lenze setting in bold)	
1	Fault
2	Trouble
3	Quick stop by trouble
5	Warning
4	Warning locked
6	Information
0	No response
<input checked="" type="checkbox"/> Read access <input checked="" type="checkbox"/> Write access <input type="checkbox"/> CINH <input type="checkbox"/> PLC-STOP <input type="checkbox"/> No transfer	

C13050

Parameter Name: C13050 Signal source DFOUT	Data type: UNSIGNED_8 Index: 11525 _d = 2D05 _h
Digital frequency extension module in module receptacle MXI1: Selection of the signal source for digital frequency output X10	
Selection list (Lenze setting in bold)	
1	None
2	Digital frequency input DFIN
3	Motor feedback system
4	Load feedback system
5	Resolver
6	Encoder
7	Application [Incr./ms]
<input checked="" type="checkbox"/> Read access <input checked="" type="checkbox"/> Write access <input type="checkbox"/> CINH <input type="checkbox"/> PLC-STOP <input type="checkbox"/> No transfer	

C13051

Parameter Name: C13051 No. of increments DFOUT	Data type: UNSIGNED_32 Index: 11524 _d = 2D04 _h
Digital frequency extension module in module receptacle MXI1: Number of increments for digital frequency output X10 <ul style="list-style-type: none"> Definition of the number of pulses for one "mechanical" revolution. 	
Setting range (min. value unit max. value)	
1	16384
Lenze setting	
2048	
<input checked="" type="checkbox"/> Read access <input checked="" type="checkbox"/> Write access <input type="checkbox"/> CINH <input type="checkbox"/> PLC-STOP <input type="checkbox"/> No transfer	

C13052

Parameter Name: C13052 Zero pulse offset DFOUT	Data type: UNSIGNED_16 Index: 11523 _d = 2D03 _h
Digital frequency extension module in module receptacle MXI1: Zero pulse offset for digital frequency output X10 <ul style="list-style-type: none"> Offset for displacing the zero pulse to be output. 	
Setting range (min. value unit max. value)	
0	Incr. 65535
Lenze setting	
0 increments	
<input checked="" type="checkbox"/> Read access <input checked="" type="checkbox"/> Write access <input checked="" type="checkbox"/> CINH <input type="checkbox"/> PLC-STOP <input type="checkbox"/> No transfer	

C13053

Parameter Name: C13053 Frequency limitation DFOUT	Data type: UNSIGNED_16 Index: 11522 _d = 2D02 _h
<p>Digital frequency extension module in module receptacle MXI1: Limit frequency for digital frequency output X10</p> <ul style="list-style-type: none"> • Frequency to which the digital frequency output is limited by the software. • If the limit value is reached, the response set in C13080 is executed. • In terms of the hardware, the digital frequency output is limited to 500 kHz. • If the digital frequency input is directly connected to the digital frequency output, the set frequency limitation is functionless! <p>Note: Du to the remainder processing implemented in the 4 kHz control cycle, only settings ≥ 4 kHz are reasonable for frequency limitation! ▶ Frequency limitation</p>	
Setting range (min. value unit max. value)	Lenze setting
1 kHz 500	500 kHz
<input checked="" type="checkbox"/> Read access <input checked="" type="checkbox"/> Write access <input type="checkbox"/> CINH <input type="checkbox"/> PLC-STOP <input type="checkbox"/> No transfer	

C13061

Parameter Name: C13061 TP delay time DFOUT	Data type: UNSIGNED_32 Index: 11514 _d = 2CFA _h
<p>Digital frequency extension module in module receptacle MXI1: Touch probe delay for digital frequency output X10</p> <ul style="list-style-type: none"> • The delay time set is considered when the position at the instant of touch probe is determined (instant of zero pulse) and serves to compensate dead times, if existent. 	
Setting range (min. value unit max. value)	Lenze setting
0 μs 7000	0 μs
<input checked="" type="checkbox"/> Read access <input checked="" type="checkbox"/> Write access <input type="checkbox"/> CINH <input type="checkbox"/> PLC-STOP <input type="checkbox"/> No transfer	

C13070

Parameter Name: C13070 Speed at DFOUT	Data type: INTEGER_32 Index: 11505 _d = 2CF1 _h
<p>Digital frequency extension module in module receptacle MXI1: Display of the current speed at digital frequency output X10</p>	
Display range (min. value unit max. value)	
-2147483648 Incr./ms 2147483647	
<input checked="" type="checkbox"/> Read access <input type="checkbox"/> Write access <input type="checkbox"/> CINH <input type="checkbox"/> PLC-STOP <input type="checkbox"/> No transfer	

C13071

Parameter Name: C13071 Frequency at DFOUT	Data type: INTEGER_32 Index: 11504 _d = 2CF0 _h
<p>Digital frequency extension module in module receptacle MXI1: Display of the current frequency at digital frequency output X10</p>	
Display range (min. value unit max. value)	
-2147483648 Hz 2147483647	
<input checked="" type="checkbox"/> Read access <input type="checkbox"/> Write access <input type="checkbox"/> CINH <input type="checkbox"/> PLC-STOP <input type="checkbox"/> No transfer	

C13072

Parameter Name: C13072 Position at DFOUT	Data type: INTEGER_32 Index: 11503 _d = 2CF _h
<p>Digital frequency extension module in module receptacle MXI1: Display of the current position at digital frequency output X10</p>	
Display range (min. value unit max. value)	
-2147483648 Incr. 2147483647	
<input checked="" type="checkbox"/> Read access <input type="checkbox"/> Write access <input type="checkbox"/> CINH <input type="checkbox"/> PLC-STOP <input type="checkbox"/> No transfer	

Digital frequency extension module | Parameter setting & configuration

Parameter reference

Parameter list | C13075

C13075

Parameter Name: C13075 Unit		Data type: VISIBLE_STRING Index: 11500 _d = 2CEC _h
Subcodes	Info	
C13075/1	Unit for the position	
C13075/2	Unit for the speed	
<input checked="" type="checkbox"/> Read access <input type="checkbox"/> Write access <input type="checkbox"/> CINH <input type="checkbox"/> PLC-STOP <input type="checkbox"/> No transfer		

C13076

Parameter Name: C13076 Actual position DFOUT		Data type: INTEGER_32 Index: 11499 _d = 2CEB _h
Display range (min. value unit max. value)		
-214748.3647	Unit	214748.3647
<input checked="" type="checkbox"/> Read access <input type="checkbox"/> Write access <input type="checkbox"/> CINH <input type="checkbox"/> PLC-STOP <input type="checkbox"/> No transfer Scaling factor: 10000		

C13077

Parameter Name: C13077 Actual speed DFOUT		Data type: INTEGER_32 Index: 11498 _d = 2CEA _h
Display range (min. value unit max. value)		
-214748.3647	Unit/s	214748.3647
<input checked="" type="checkbox"/> Read access <input type="checkbox"/> Write access <input type="checkbox"/> CINH <input type="checkbox"/> PLC-STOP <input type="checkbox"/> No transfer Scaling factor: 10000		

C13080

Parameter Name: C13080 Resp. to freq. limit. DFOUT		Data type: UNSIGNED_8 Index: 11495 _d = 2CE7 _h
Digital frequency extension module in module receptacle MXI1: Response when limit frequency for digital frequency output X10 is reached. <ul style="list-style-type: none"> • Is executed if the digital frequency reaches the limit value set in C13053. 		
Selection list (Lenze setting in bold)		
1	Fault	
2	Trouble	
3	Quick stop by trouble	
5	Warning	
4	Warning locked	
6	Information	
0	No response	
<input checked="" type="checkbox"/> Read access <input checked="" type="checkbox"/> Write access <input type="checkbox"/> CINH <input type="checkbox"/> PLC-STOP <input type="checkbox"/> No transfer		

C14010

Parameter Name: C14010 Encoder type DFIN	Data type: UNSIGNED_8 Index: 10565 _d = 2945 _h
Digital frequency extension module in module receptacle MXI2: Selection of the encoder type for digital frequency input X9	
Selection list (Lenze setting in bold)	
1	Digital frequency output DFOUT
2	TTL encoder
<input checked="" type="checkbox"/> Read access <input checked="" type="checkbox"/> Write access <input type="checkbox"/> CINH <input type="checkbox"/> PLC-STOP <input type="checkbox"/> No transfer	

C14011

Parameter Name: C14011 No. of increments DFIN	Data type: UNSIGNED_32 Index: 10564 _d = 2944 _h
Digital frequency extension module in module receptacle MXI2: Number of increments for digital frequency input X9 <ul style="list-style-type: none"> • Definition of the number of pulses for one "mechanical" revolution. 	
Setting range (min. value unit max. value)	
1	16384
Lenze setting	
2048	
<input checked="" type="checkbox"/> Read access <input checked="" type="checkbox"/> Write access <input type="checkbox"/> CINH <input type="checkbox"/> PLC-STOP <input type="checkbox"/> No transfer	

C14012

Parameter Name: C14012 Signal format DFIN	Data type: UNSIGNED_8 Index: 10563 _d = 2943 _h
Digital frequency extension module in module receptacle MXI2: Signal form for digital frequency input X9 <ul style="list-style-type: none"> • Selection of how to interpret the input signal. 	
Selection list (Lenze setting in bold)	
0	4x evaluation (A, B)
1	A:Increments B:Sign
2	Increments A:pos. B:neg.
<input checked="" type="checkbox"/> Read access <input checked="" type="checkbox"/> Write access <input type="checkbox"/> CINH <input type="checkbox"/> PLC-STOP <input type="checkbox"/> No transfer	

C14013

Parameter Name: C14013 Initialisation time DFIN	Data type: UNSIGNED_16 Index: 10562 _d = 2942 _h
Digital frequency extension module in module receptacle MXI2: Initialisation time for digital frequency input X9 <ul style="list-style-type: none"> • Waiting time after which the "Enable" signal is evaluated and the track monitoring modes are switched active. 	
Setting range (min. value unit max. value)	
0	65535
ms	
Lenze setting	
3000 ms	
<input checked="" type="checkbox"/> Read access <input checked="" type="checkbox"/> Write access <input type="checkbox"/> CINH <input type="checkbox"/> PLC-STOP <input type="checkbox"/> No transfer	

C14014

Parameter Name: C14014 Track monitoring DFIN	Data type: UNSIGNED_8 Index: 10561 _d = 2941 _h
Digital frequency extension module in module receptacle MXI2: Monitoring configuration for digital frequency input X9 <ul style="list-style-type: none"> • Selection when track monitoring modes (open circuit detection) are active. 	
Selection list (Lenze setting in bold)	
1	Active after initialisation time
2	Active after enable signal
<input checked="" type="checkbox"/> Read access <input checked="" type="checkbox"/> Write access <input type="checkbox"/> CINH <input type="checkbox"/> PLC-STOP <input type="checkbox"/> No transfer	

Digital frequency extension module | Parameter setting & configuration

Parameter reference

Parameter list | C14015

C14015

Parameter Name: C14015 Encoder mounting dir. (DFIN)		Data type: UNSIGNED_32 Index: 10560 _d = 2940 _h
Selection list (Lenze setting in bold)		Info
0	Clockwise direction of rotation	
1	Counter-clockwise direction of rotation	
<input checked="" type="checkbox"/> Read access <input checked="" type="checkbox"/> Write access <input checked="" type="checkbox"/> CINH <input type="checkbox"/> PLC-STOP <input type="checkbox"/> No transfer		

C14021

Parameter Name: C14021 TP delay time DFIN		Data type: UNSIGNED_32 Index: 10554 _d = 293A _h
Digital frequency extension module in module receptacle MXI2: Touch probe delay for digital frequency input X9 • The delay time set is considered when the position at the instant of touch probe is determined (instant of zero pulse) and serves to compensate dead times, if existent.		
Setting range (min. value unit max. value)		Lenze setting
0	µs	7000 0 µs
<input checked="" type="checkbox"/> Read access <input checked="" type="checkbox"/> Write access <input type="checkbox"/> CINH <input type="checkbox"/> PLC-STOP <input type="checkbox"/> No transfer		

C14030

Parameter Name: C14030 Speed at DFIN		Data type: INTEGER_32 Index: 10545 _d = 2931 _h
Digital frequency extension module in module receptacle MXI2: Display of the current speed at digital frequency input X9		
Display range (min. value unit max. value)		
-2147483648	Incr./ms	2147483647
<input checked="" type="checkbox"/> Read access <input type="checkbox"/> Write access <input type="checkbox"/> CINH <input type="checkbox"/> PLC-STOP <input type="checkbox"/> No transfer		

C14031

Parameter Name: C14031 Frequency at DFIN		Data type: INTEGER_32 Index: 10544 _d = 2930 _h
Digital frequency extension module in module receptacle MXI2: Display of the current frequency at digital frequency input X9		
Display range (min. value unit max. value)		
-2147483648	Hz	2147483647
<input checked="" type="checkbox"/> Read access <input type="checkbox"/> Write access <input type="checkbox"/> CINH <input type="checkbox"/> PLC-STOP <input type="checkbox"/> No transfer		

C14032

Parameter Name: C14032 Position at DFIN		Data type: INTEGER_32 Index: 10543 _d = 292F _h
Digital frequency extension module in module receptacle MXI2: Display of the current position at digital frequency input X9		
Display range (min. value unit max. value)		
-2147483648	Incr.	2147483647
<input checked="" type="checkbox"/> Read access <input type="checkbox"/> Write access <input type="checkbox"/> CINH <input type="checkbox"/> PLC-STOP <input type="checkbox"/> No transfer		

C14035

Parameter Name: C14035 Unit		Data type: VISIBLE_STRING Index: 10540 _d = 292C _h
Subcodes		Info
C14035/1		Unit for the position
C14035/2		Unit for the speed
<input checked="" type="checkbox"/> Read access <input type="checkbox"/> Write access <input type="checkbox"/> CINH <input type="checkbox"/> PLC-STOP <input type="checkbox"/> No transfer		

C14036

Parameter Name: C14036 Actual position DFIN		Data type: INTEGER_32 Index: 10539 _d = 292B _h
Display range (min. value unit max. value)		
-214748.3647	Unit	214748.3647
<input checked="" type="checkbox"/> Read access <input type="checkbox"/> Write access <input type="checkbox"/> CINH <input type="checkbox"/> PLC-STOP <input type="checkbox"/> No transfer		Scaling factor: 10000

C14037

Parameter Name: C14037 Actual speed DFIN		Data type: INTEGER_32 Index: 10538 _d = 292A _h
Display range (min. value unit max. value)		
-214748.3647	Unit/s	214748.3647
<input checked="" type="checkbox"/> Read access <input type="checkbox"/> Write access <input type="checkbox"/> CINH <input type="checkbox"/> PLC-STOP <input type="checkbox"/> No transfer		Scaling factor: 10000

C14040

Parameter Name: C14040 Resp. to track monitoring DFIN		Data type: UNSIGNED_8 Index: 10535 _d = 2927 _h
Digital frequency extension module in module receptacle MXI2:		
Response when track monitoring is triggered for digital frequency input X9		
<ul style="list-style-type: none"> Track monitoring is triggered if a signal cable (A, B, or Z) is interrupted. 		
Selection list (Lenze setting in bold)		
1	Fault	
2	Trouble	
3	Quick stop by trouble	
5	Warning	
4	Warning locked	
6	Information	
0	No response	
<input checked="" type="checkbox"/> Read access <input checked="" type="checkbox"/> Write access <input type="checkbox"/> CINH <input type="checkbox"/> PLC-STOP <input type="checkbox"/> No transfer		

C14041

Parameter Name: C14041 Resp. to DFIN enable sig. miss.		Data type: UNSIGNED_8 Index: 10534 _d = 2926 _h
Digital frequency extension module in module receptacle MXI2:		
Response when "Enable" signal at digital frequency input X9 fails		
Selection list (Lenze setting in bold)		
1	Fault	
2	Trouble	
3	Quick stop by trouble	
5	Warning	
4	Warning locked	
6	Information	
0	No response	
<input checked="" type="checkbox"/> Read access <input checked="" type="checkbox"/> Write access <input type="checkbox"/> CINH <input type="checkbox"/> PLC-STOP <input type="checkbox"/> No transfer		

Digital frequency extension module | Parameter setting & configuration

Parameter reference

Parameter list | C14042

C14042

Parameter Name: C14042 Resp. to Vcc error DFIN	Data type: UNSIGNED_8 Index: 10533 _d = 2925 _h
Digital frequency extension module in module receptacle MXI2: Response when monitoring for encoder voltage supply at digital frequency input X9 is triggered <ul style="list-style-type: none"> Monitoring is triggered if the encoder voltage controlled by the digital frequency input reaches the voltage limit. 	
Selection list (Lenze setting in bold)	
1	Fault
2	Trouble
3	Quick stop by trouble
5	Warning
4	Warning locked
6	Information
0	No response
<input checked="" type="checkbox"/> Read access <input checked="" type="checkbox"/> Write access <input type="checkbox"/> CINH <input type="checkbox"/> PLC-STOP <input type="checkbox"/> No transfer	

C14050

Parameter Name: C14050 Signal source DFOUT	Data type: UNSIGNED_8 Index: 10525 _d = 291D _h
Digital frequency extension module in module receptacle MXI2: Selection of the signal source for digital frequency output X10	
Selection list (Lenze setting in bold)	
1	None
2	Digital frequency input DFIN
3	Motor feedback system
4	Load feedback system
5	Resolver
6	Encoder
7	Application [Incr./ms]
<input checked="" type="checkbox"/> Read access <input checked="" type="checkbox"/> Write access <input type="checkbox"/> CINH <input type="checkbox"/> PLC-STOP <input type="checkbox"/> No transfer	

C14051

Parameter Name: C14051 No. of increments DFOUT	Data type: UNSIGNED_32 Index: 10524 _d = 291C _h
Digital frequency extension module in module receptacle MXI2: Number of increments for digital frequency output X10 <ul style="list-style-type: none"> Definition of the number of pulses for one "mechanical" revolution. 	
Setting range (min. value unit max. value)	Lenze setting
1	16384 2048
<input checked="" type="checkbox"/> Read access <input checked="" type="checkbox"/> Write access <input type="checkbox"/> CINH <input type="checkbox"/> PLC-STOP <input type="checkbox"/> No transfer	

C14052

Parameter Name: C14052 Zero pulse offset DFOUT	Data type: UNSIGNED_16 Index: 10523 _d = 291B _h
Digital frequency extension module in module receptacle MXI2: Zero pulse offset for digital frequency output X10 <ul style="list-style-type: none"> Offset for displacing the zero pulse to be output. 	
Setting range (min. value unit max. value)	Lenze setting
0	Incr. 65535 0 increments
<input checked="" type="checkbox"/> Read access <input checked="" type="checkbox"/> Write access <input checked="" type="checkbox"/> CINH <input type="checkbox"/> PLC-STOP <input type="checkbox"/> No transfer	

C14053

Parameter Name: C14053 Frequency limitation DFOUT	Data type: UNSIGNED_16 Index: 10522 _d = 291A _h
Digital frequency extension module in module receptacle MXI2: Limit frequency for digital frequency output X10	
<ul style="list-style-type: none"> • Frequency to which the digital frequency output is limited by the software. • If the limit value is reached, the response set in C14080 is executed. • In terms of the hardware, the digital frequency output is limited to 500 kHz. • If the digital frequency input is directly connected to the digital frequency output, the set frequency limitation is functionless! 	
Note: Du to the remainder processing implemented in the 4 kHz control cycle, only settings ≥ 4 kHz are reasonable for frequency limitation!	
▶ Frequency limitation	
Setting range (min. value unit max. value)	Lenze setting
1 kHz 500	500 kHz
<input checked="" type="checkbox"/> Read access <input checked="" type="checkbox"/> Write access <input type="checkbox"/> CINH <input type="checkbox"/> PLC-STOP <input type="checkbox"/> No transfer	

C14061

Parameter Name: C14061 TP delay time DFOUT	Data type: UNSIGNED_32 Index: 10514 _d = 2912 _h
Digital frequency extension module in module receptacle MXI2: Touch probe delay for digital frequency output X10	
<ul style="list-style-type: none"> • The delay time set is considered when the position at the instant of touch probe is determined (instant of zero pulse) and serves to compensate dead times, if existent. 	
Setting range (min. value unit max. value)	Lenze setting
0 μs 7000	0 μs
<input checked="" type="checkbox"/> Read access <input checked="" type="checkbox"/> Write access <input type="checkbox"/> CINH <input type="checkbox"/> PLC-STOP <input type="checkbox"/> No transfer	

C14070

Parameter Name: C14070 Speed at DFOUT	Data type: INTEGER_32 Index: 10505 _d = 2909 _h
Digital frequency extension module in module receptacle MXI2: Display of the current speed at digital frequency output X10	
Display range (min. value unit max. value)	
-2147483648 Incr./ms 2147483647	
<input checked="" type="checkbox"/> Read access <input type="checkbox"/> Write access <input type="checkbox"/> CINH <input type="checkbox"/> PLC-STOP <input type="checkbox"/> No transfer	

C14071

Parameter Name: C14071 Frequency at DFOUT	Data type: INTEGER_32 Index: 10504 _d = 2908 _h
Digital frequency extension module in module receptacle MXI2: Display of the current frequency at digital frequency output X10	
Display range (min. value unit max. value)	
-2147483648 Hz 2147483647	
<input checked="" type="checkbox"/> Read access <input type="checkbox"/> Write access <input type="checkbox"/> CINH <input type="checkbox"/> PLC-STOP <input type="checkbox"/> No transfer	

C14072

Parameter Name: C14072 Position at DFOUT	Data type: INTEGER_32 Index: 10503 _d = 2907 _h
Digital frequency extension module in module receptacle MXI2: Display of the current position at digital frequency output X10	
Display range (min. value unit max. value)	
-2147483648 Incr. 2147483647	
<input checked="" type="checkbox"/> Read access <input type="checkbox"/> Write access <input type="checkbox"/> CINH <input type="checkbox"/> PLC-STOP <input type="checkbox"/> No transfer	

Digital frequency extension module | Parameter setting & configuration

Parameter reference

Parameter list | C14075

C14075

Parameter Name: C14075 Unit		Data type: VISIBLE_STRING Index: 10500 _d = 2904 _h
Subcodes	Info	
C14075/1	Unit for the position	
C14075/2	Unit for the speed	
<input checked="" type="checkbox"/> Read access <input type="checkbox"/> Write access <input type="checkbox"/> CINH <input type="checkbox"/> PLC-STOP <input type="checkbox"/> No transfer		

C14076

Parameter Name: C14076 Actual position DFOUT		Data type: INTEGER_32 Index: 10499 _d = 2903 _h
Display range (min. value unit max. value)		
-214748.3647	Unit	214748.3647
<input checked="" type="checkbox"/> Read access <input type="checkbox"/> Write access <input type="checkbox"/> CINH <input type="checkbox"/> PLC-STOP <input type="checkbox"/> No transfer Scaling factor: 10000		

C14077

Parameter Name: C14077 Actual speed DFOUT		Data type: INTEGER_32 Index: 10498 _d = 2902 _h
Display range (min. value unit max. value)		
-214748.3647	Unit/s	214748.3647
<input checked="" type="checkbox"/> Read access <input type="checkbox"/> Write access <input type="checkbox"/> CINH <input type="checkbox"/> PLC-STOP <input type="checkbox"/> No transfer Scaling factor: 10000		

C14080

Parameter Name: C14080 Resp. to freq. limit. DFOUT		Data type: UNSIGNED_8 Index: 10495 _d = 28FF _h
Digital frequency extension module in module receptacle MX12: Response when limit frequency for digital frequency output X10 is reached. <ul style="list-style-type: none"> • Is executed if the digital frequency reaches the limit value set in C14053. 		
Selection list (Lenze setting in bold)		
1	Fault	
2	Trouble	
3	Quick stop by trouble	
5	Warning	
4	Warning locked	
6	Information	
0	No response	
<input checked="" type="checkbox"/> Read access <input checked="" type="checkbox"/> Write access <input type="checkbox"/> CINH <input type="checkbox"/> PLC-STOP <input type="checkbox"/> No transfer		

4.2 Table of attributes

The table of attributes contains information required for communicating with the controller via parameters.

How to read the table of attributes:

Column		Meaning	Entry	
Code		Parameter designation	Cxxxxx	
Name		Short parameter text (display text)	Text	
Index	dec	Index under which the parameter is addressed. The subindex of array variables corresponds to the Lenze subcode number.	24575 - Lenze code number	Only required for access via bus system.
	hex		5FFF _n - Lenze code number	
Data	DS	Data structure	E	Single variable (only one parameter element)
			A	Array variable (several parameter elements)
	DA	Number of array elements (subcodes)	Number	
	DT	Data type	BITFIELD_8	1 byte bit-coded
			BITFIELD_16	2 bytes bit-coded
			BITFIELD_32	4 bytes bit-coded
			INTEGER_8	1 byte with sign
			INTEGER_16	2 bytes with sign
			INTEGER_32	4 bytes with sign
			UNSIGNED_8	1 byte without sign
UNSIGNED_16			2 bytes without sign	
UNSIGNED_32	4 bytes without sign			
VISIBLE_STRING	ASCII string			
Factor	Factor for data transmission via bus system, depending on the number of decimal positions.	Factor	1 = no decimal positions 10 = 1 decimal position 100 = 2 decimal positions 1000 = 3 decimal positions	
Access	R	Read access	<input checked="" type="checkbox"/> Reading allowed	
	W	Write access	<input checked="" type="checkbox"/> Writing allowed	
	CINH	Controller inhibit required	<input checked="" type="checkbox"/> Writing only possible when controller is inhibited	

Digital frequency extension module | Parameter setting & configuration

Parameter reference

Table of attributes

Table of attributes

Code	Name	Index		Data				Access		
		dec	hex	DS	DA	DT	Factor	R	W	CINH
C13010	Encoder type DFIN	11565	2D2D	E	1	UNSIGNED_8	1	<input checked="" type="checkbox"/>	<input checked="" type="checkbox"/>	
C13011	No. of increments DFIN	11564	2D2C	E	1	UNSIGNED_32	1	<input checked="" type="checkbox"/>	<input checked="" type="checkbox"/>	
C13012	Signal format DFIN	11563	2D2B	E	1	UNSIGNED_8	1	<input checked="" type="checkbox"/>	<input checked="" type="checkbox"/>	
C13013	Initialisation time DFIN	11562	2D2A	E	1	UNSIGNED_16	1	<input checked="" type="checkbox"/>	<input checked="" type="checkbox"/>	
C13014	Track monitoring DFIN	11561	2D29	E	1	UNSIGNED_8	1	<input checked="" type="checkbox"/>	<input checked="" type="checkbox"/>	
C13015	Encoder mounting dir. (DFIN)	11560	2D28	E	1	UNSIGNED_32	1	<input checked="" type="checkbox"/>	<input checked="" type="checkbox"/>	<input checked="" type="checkbox"/>
C13021	TP delay time DFIN	11554	2D22	E	1	UNSIGNED_32	1	<input checked="" type="checkbox"/>	<input checked="" type="checkbox"/>	
C13030	Speed at DFIN	11545	2D19	E	1	INTEGER_32	1	<input checked="" type="checkbox"/>		
C13031	Frequency at DFIN	11544	2D18	E	1	INTEGER_32	1	<input checked="" type="checkbox"/>		
C13032	Position at DFIN	11543	2D17	E	1	INTEGER_32	1	<input checked="" type="checkbox"/>		
C13035	Unit	11540	2D14	A	2	VISIBLE_STRING		<input checked="" type="checkbox"/>		
C13036	Actual position DFIN	11539	2D13	E	1	INTEGER_32	10000	<input checked="" type="checkbox"/>		
C13037	Actual speed DFIN	11538	2D12	E	1	INTEGER_32	10000	<input checked="" type="checkbox"/>		
C13040	Resp. to track monitoring DFIN	11535	2D0F	E	1	UNSIGNED_8	1	<input checked="" type="checkbox"/>	<input checked="" type="checkbox"/>	
C13041	Resp. to DFIN enable sig. miss.	11534	2D0E	E	1	UNSIGNED_8	1	<input checked="" type="checkbox"/>	<input checked="" type="checkbox"/>	
C13042	Resp. to Vcc error DFIN	11533	2D0D	E	1	UNSIGNED_8	1	<input checked="" type="checkbox"/>	<input checked="" type="checkbox"/>	
C13050	Signal source DFOUT	11525	2D05	E	1	UNSIGNED_8	1	<input checked="" type="checkbox"/>	<input checked="" type="checkbox"/>	
C13051	No. of increments DFOUT	11524	2D04	E	1	UNSIGNED_32	1	<input checked="" type="checkbox"/>	<input checked="" type="checkbox"/>	
C13052	Zero pulse offset DFOUT	11523	2D03	E	1	UNSIGNED_16	1	<input checked="" type="checkbox"/>	<input checked="" type="checkbox"/>	<input checked="" type="checkbox"/>
C13053	Frequency limitation DFOUT	11522	2D02	E	1	UNSIGNED_16	1	<input checked="" type="checkbox"/>	<input checked="" type="checkbox"/>	
C13061	TP delay time DFOUT	11514	2CFA	E	1	UNSIGNED_32	1	<input checked="" type="checkbox"/>	<input checked="" type="checkbox"/>	
C13070	Speed at DFOUT	11505	2CF1	E	1	INTEGER_32	1	<input checked="" type="checkbox"/>		
C13071	Frequency at DFOUT	11504	2CF0	E	1	INTEGER_32	1	<input checked="" type="checkbox"/>		
C13072	Position at DFOUT	11503	2CEF	E	1	INTEGER_32	1	<input checked="" type="checkbox"/>		
C13075	Unit	11500	2CEC	A	2	VISIBLE_STRING		<input checked="" type="checkbox"/>		
C13076	Actual position DFOUT	11499	2CEB	E	1	INTEGER_32	10000	<input checked="" type="checkbox"/>		
C13077	Actual speed DFOUT	11498	2CEA	E	1	INTEGER_32	10000	<input checked="" type="checkbox"/>		
C13080	Resp. to freq. limit. DFOUT	11495	2CE7	E	1	UNSIGNED_8	1	<input checked="" type="checkbox"/>	<input checked="" type="checkbox"/>	
C14010	Encoder type DFIN	10565	2945	E	1	UNSIGNED_8	1	<input checked="" type="checkbox"/>	<input checked="" type="checkbox"/>	
C14011	No. of increments DFIN	10564	2944	E	1	UNSIGNED_32	1	<input checked="" type="checkbox"/>	<input checked="" type="checkbox"/>	
C14012	Signal format DFIN	10563	2943	E	1	UNSIGNED_8	1	<input checked="" type="checkbox"/>	<input checked="" type="checkbox"/>	
C14013	Initialisation time DFIN	10562	2942	E	1	UNSIGNED_16	1	<input checked="" type="checkbox"/>	<input checked="" type="checkbox"/>	
C14014	Track monitoring DFIN	10561	2941	E	1	UNSIGNED_8	1	<input checked="" type="checkbox"/>	<input checked="" type="checkbox"/>	
C14015	Encoder mounting dir. (DFIN)	10560	2940	E	1	UNSIGNED_32	1	<input checked="" type="checkbox"/>	<input checked="" type="checkbox"/>	<input checked="" type="checkbox"/>
C14021	TP delay time DFIN	10554	293A	E	1	UNSIGNED_32	1	<input checked="" type="checkbox"/>	<input checked="" type="checkbox"/>	
C14030	Speed at DFIN	10545	2931	E	1	INTEGER_32	1	<input checked="" type="checkbox"/>		
C14031	Frequency at DFIN	10544	2930	E	1	INTEGER_32	1	<input checked="" type="checkbox"/>		
C14032	Position at DFIN	10543	292F	E	1	INTEGER_32	1	<input checked="" type="checkbox"/>		
C14035	Unit	10540	292C	A	2	VISIBLE_STRING		<input checked="" type="checkbox"/>		
C14036	Actual position DFIN	10539	292B	E	1	INTEGER_32	10000	<input checked="" type="checkbox"/>		
C14037	Actual speed DFIN	10538	292A	E	1	INTEGER_32	10000	<input checked="" type="checkbox"/>		
C14040	Resp. to track monitoring DFIN	10535	2927	E	1	UNSIGNED_8	1	<input checked="" type="checkbox"/>	<input checked="" type="checkbox"/>	
C14041	Resp. to DFIN enable sig. miss.	10534	2926	E	1	UNSIGNED_8	1	<input checked="" type="checkbox"/>	<input checked="" type="checkbox"/>	
C14042	Resp. to Vcc error DFIN	10533	2925	E	1	UNSIGNED_8	1	<input checked="" type="checkbox"/>	<input checked="" type="checkbox"/>	
C14050	Signal source DFOUT	10525	291D	E	1	UNSIGNED_8	1	<input checked="" type="checkbox"/>	<input checked="" type="checkbox"/>	
C14051	No. of increments DFOUT	10524	291C	E	1	UNSIGNED_32	1	<input checked="" type="checkbox"/>	<input checked="" type="checkbox"/>	
C14052	Zero pulse offset DFOUT	10523	291B	E	1	UNSIGNED_16	1	<input checked="" type="checkbox"/>	<input checked="" type="checkbox"/>	<input checked="" type="checkbox"/>
C14053	Frequency limitation DFOUT	10522	291A	E	1	UNSIGNED_16	1	<input checked="" type="checkbox"/>	<input checked="" type="checkbox"/>	
C14061	TP delay time DFOUT	10514	2912	E	1	UNSIGNED_32	1	<input checked="" type="checkbox"/>	<input checked="" type="checkbox"/>	

Code	Name	Index		Data				Access		
		dec	hex	DS	DA	DT	Factor	R	W	CINH
C14070	Speed at DFOUT	10505	2909	E	1	INTEGER_32	1	<input checked="" type="checkbox"/>		
C14071	Frequency at DFOUT	10504	2908	E	1	INTEGER_32	1	<input checked="" type="checkbox"/>		
C14072	Position at DFOUT	10503	2907	E	1	INTEGER_32	1	<input checked="" type="checkbox"/>		
C14075	Unit	10500	2904	A	2	VISIBLE_STRING		<input checked="" type="checkbox"/>		
C14076	Actual position DFOUT	10499	2903	E	1	INTEGER_32	10000	<input checked="" type="checkbox"/>		
C14077	Actual speed DFOUT	10498	2902	E	1	INTEGER_32	10000	<input checked="" type="checkbox"/>		
C14080	Resp. to freq. limit. DFOUT	10495	28FF	E	1	UNSIGNED_8	1	<input checked="" type="checkbox"/>	<input checked="" type="checkbox"/>	

5 Fault messages



Note!

This chapter completes the fault list in the online documentation for the controller by fault messages concerning the digital frequency extension module.



Tip!

General information on diagnostics & fault analysis and fault messages can be found in the online documentation for the controller.

DFIN (MXI1): Track error A-/A [0x00990000]

Response (Lenze setting in bold)		Setting: C13040 (<input checked="" type="checkbox"/> Adjustable response)
<input checked="" type="checkbox"/> No <input type="checkbox"/> System fault <input checked="" type="checkbox"/> Fault <input checked="" type="checkbox"/> Trouble <input checked="" type="checkbox"/> Quick stop by trouble <input checked="" type="checkbox"/> Warning locked <input checked="" type="checkbox"/> Warning <input checked="" type="checkbox"/> Information		
Cause	Remedy	
Digital frequency extension module in MXI1: Interruption (open circuit) of signal cable for track A.	<ul style="list-style-type: none"> • Check signal cable for track A. • Check encoder. 	

DFIN (MXI1): Track error B-/B [0x00990001]

Response (Lenze setting in bold)		Setting: C13040 (<input checked="" type="checkbox"/> Adjustable response)
<input checked="" type="checkbox"/> No <input type="checkbox"/> System fault <input checked="" type="checkbox"/> Fault <input checked="" type="checkbox"/> Trouble <input checked="" type="checkbox"/> Quick stop by trouble <input checked="" type="checkbox"/> Warning locked <input checked="" type="checkbox"/> Warning <input checked="" type="checkbox"/> Information		
Cause	Remedy	
Digital frequency extension module in MXI1: Interruption (open circuit) of signal cable for track B.	<ul style="list-style-type: none"> • Check signal cable for track B. • Check encoder. 	

DFIN (MXI1): Track error Z-/Z [0x00990002]

Response (Lenze setting in bold)		Setting: C13040 (<input checked="" type="checkbox"/> Adjustable response)
<input checked="" type="checkbox"/> No <input type="checkbox"/> System fault <input checked="" type="checkbox"/> Fault <input checked="" type="checkbox"/> Trouble <input checked="" type="checkbox"/> Quick stop by trouble <input checked="" type="checkbox"/> Warning locked <input checked="" type="checkbox"/> Warning <input checked="" type="checkbox"/> Information		
Cause	Remedy	
Digital frequency extension module in MXI1: Interruption (open circuit) of signal cable for track Z.	<ul style="list-style-type: none"> • Check signal cable for track Z. • Check encoder. 	

DFIN (MXI1): Signal error enable/lamp control [0x00990003]

Response (Lenze setting in bold)		Setting: C13041 (<input checked="" type="checkbox"/> Adjustable response)
<input checked="" type="checkbox"/> No <input type="checkbox"/> System fault <input checked="" type="checkbox"/> Fault <input checked="" type="checkbox"/> Trouble <input checked="" type="checkbox"/> Quick stop by trouble <input checked="" type="checkbox"/> Warning locked <input checked="" type="checkbox"/> Warning <input checked="" type="checkbox"/> Information		
Cause	Remedy	
Digital frequency extension module in MXI1: Interruption (open circuit) of signal cable for "Enable" signal or no "Enable" signal available.	<ul style="list-style-type: none"> • Check signal cable for "Enable" signal. • Check encoder. 	

DFIN (MXI1): Supply cannot be corrected anymore [0x00990004]

Response (Lenze setting in bold)		Setting: C13042 (<input checked="" type="checkbox"/> Adjustable response)
<input checked="" type="checkbox"/> No <input type="checkbox"/> System fault <input checked="" type="checkbox"/> Fault <input checked="" type="checkbox"/> Trouble <input checked="" type="checkbox"/> Quick stop by trouble <input checked="" type="checkbox"/> Warning locked <input checked="" type="checkbox"/> Warning <input checked="" type="checkbox"/> Information		
Cause	Remedy	
Digital frequency extension module in MXI1: The encoder voltage controlled by the digital frequency input has reached the voltage limit.	Check encoder.	

DFOUT (MXI1): Maximum frequency reached [0x00990005]

Response (Lenze setting in bold)		Setting: C13080 (<input checked="" type="checkbox"/> Adjustable response)
<input checked="" type="checkbox"/> No <input type="checkbox"/> System fault <input checked="" type="checkbox"/> Fault <input checked="" type="checkbox"/> Trouble <input checked="" type="checkbox"/> Quick stop by trouble <input checked="" type="checkbox"/> Warning locked <input checked="" type="checkbox"/> Warning <input checked="" type="checkbox"/> Information		
Cause	Remedy	
Digital frequency extension module in MXI1: Limit frequency at the digital frequency output reached. <ul style="list-style-type: none"> • The digital frequency has reached the limit value set in C013053. 	Check set limit value.	

Digital frequency extension module | Parameter setting & configuration

Fault messages

DFIN (MXI2): Track error A-/A [0x00aa0000]

Response (Lenze setting in bold) Setting: C14040 (<input checked="" type="checkbox"/> Adjustable response)	
<input checked="" type="checkbox"/> No <input type="checkbox"/> System fault <input checked="" type="checkbox"/> Fault <input checked="" type="checkbox"/> Trouble <input checked="" type="checkbox"/> Quick stop by trouble <input checked="" type="checkbox"/> Warning locked <input checked="" type="checkbox"/> Warning <input checked="" type="checkbox"/> Information	
Cause	Remedy
Digital frequency extension module in MXI2: Interruption (open circuit) of signal cable for track A.	<ul style="list-style-type: none">• Check signal cable for track A.• Check encoder.

DFIN (MXI2): Track error B-/B [0x00aa0001]

Response (Lenze setting in bold) Setting: C14040 (<input checked="" type="checkbox"/> Adjustable response)	
<input checked="" type="checkbox"/> No <input type="checkbox"/> System fault <input checked="" type="checkbox"/> Fault <input checked="" type="checkbox"/> Trouble <input checked="" type="checkbox"/> Quick stop by trouble <input checked="" type="checkbox"/> Warning locked <input checked="" type="checkbox"/> Warning <input checked="" type="checkbox"/> Information	
Cause	Remedy
Digital frequency extension module in MXI2: Interruption (open circuit) of signal cable for track B.	<ul style="list-style-type: none">• Check signal cable for track B.• Check encoder.

DFIN (MXI2): Track error Z-/Z [0x00aa0002]

Response (Lenze setting in bold) Setting: C14040 (<input checked="" type="checkbox"/> Adjustable response)	
<input checked="" type="checkbox"/> No <input type="checkbox"/> System fault <input checked="" type="checkbox"/> Fault <input checked="" type="checkbox"/> Trouble <input checked="" type="checkbox"/> Quick stop by trouble <input checked="" type="checkbox"/> Warning locked <input checked="" type="checkbox"/> Warning <input checked="" type="checkbox"/> Information	
Cause	Remedy
Digital frequency extension module in MXI2: Interruption (open circuit) of signal cable for track Z.	<ul style="list-style-type: none">• Check signal cable for track Z.• Check encoder.

DFIN (MXI2): Signal error enable/lamp control [0x00aa0003]

Response (Lenze setting in bold) Setting: C14041 (<input checked="" type="checkbox"/> Adjustable response)	
<input checked="" type="checkbox"/> No <input type="checkbox"/> System fault <input checked="" type="checkbox"/> Fault <input checked="" type="checkbox"/> Trouble <input checked="" type="checkbox"/> Quick stop by trouble <input checked="" type="checkbox"/> Warning locked <input checked="" type="checkbox"/> Warning <input checked="" type="checkbox"/> Information	
Cause	Remedy
Digital frequency extension module in MXI2: Interruption (open circuit) of signal cable for "Enable" signal or no "Enable" signal available.	<ul style="list-style-type: none">• Check signal cable for "Enable" signal.• Check encoder.

DFIN (MXI2): Supply cannot be corrected anymore [0x00aa0004]

Response (Lenze setting in bold) Setting: C14042 (<input checked="" type="checkbox"/> Adjustable response)	
<input checked="" type="checkbox"/> No <input type="checkbox"/> System fault <input checked="" type="checkbox"/> Fault <input checked="" type="checkbox"/> Trouble <input checked="" type="checkbox"/> Quick stop by trouble <input checked="" type="checkbox"/> Warning locked <input checked="" type="checkbox"/> Warning <input checked="" type="checkbox"/> Information	
Cause	Remedy
Digital frequency extension module in MXI2: The encoder voltage controlled by the digital frequency input has reached the voltage limit.	Check encoder.

DFOUT (MXI2): Maximum frequency reached [0x00aa0005]

Response (Lenze setting in bold) Setting: C14080 (<input checked="" type="checkbox"/> Adjustable response)	
<input checked="" type="checkbox"/> No <input type="checkbox"/> System fault <input checked="" type="checkbox"/> Fault <input checked="" type="checkbox"/> Trouble <input checked="" type="checkbox"/> Quick stop by trouble <input checked="" type="checkbox"/> Warning locked <input checked="" type="checkbox"/> Warning <input checked="" type="checkbox"/> Information	
Cause	Remedy
Digital frequency extension module in MXI2: Limit frequency at the digital frequency output reached. <ul style="list-style-type: none">• The digital frequency has reached the limit value set in C014053.	Check set limit value.

6 Index

A

Actual position DFIN (C13036) [35](#)
 Actual position DFIN (C14036) [41](#)
 Actual position DFOUT (C13076) [38](#)
 Actual position DFOUT (C14076) [44](#)
 Actual speed DFIN (C13037) [35](#)
 Actual speed DFIN (C14037) [41](#)
 Actual speed DFOUT (C13077) [38](#)
 Actual speed DFOUT (C14077) [44](#)
 Application notes [8](#)

C

C13010 [33](#)
 C13011 [33](#)
 C13012 [33](#)
 C13013 [33](#)
 C13014 [33](#)
 C13015 [34](#)
 C13021 [34](#)
 C13030 [34](#)
 C13031 [34](#)
 C13032 [34](#)
 C13035 [34](#)
 C13036 [35](#)
 C13037 [35](#)
 C13040 [35](#)
 C13041 [35](#)
 C13042 [36](#)
 C13050 [36](#)
 C13051 [36](#)
 C13052 [36](#)
 C13053 [37](#)
 C13061 [37](#)
 C13070 [37](#)
 C13071 [37](#)
 C13072 [37](#)
 C13075 [38](#)
 C13076 [38](#)
 C13077 [38](#)
 C13080 [38](#)
 C14010 [39](#)
 C14011 [39](#)
 C14012 [39](#)
 C14013 [39](#)
 C14014 [39](#)
 C14015 [40](#)
 C14021 [40](#)
 C14030 [40](#)
 C14031 [40](#)
 C14032 [40](#)
 C14035 [40](#)

C14036 [41](#)
 C14037 [41](#)
 C14040 [41](#)
 C14041 [41](#)
 C14042 [42](#)
 C14050 [42](#)
 C14051 [42](#)
 C14052 [42](#)
 C14053 [43](#)
 C14061 [43](#)
 C14070 [43](#)
 C14071 [43](#)
 C14072 [43](#)
 C14075 [44](#)
 C14076 [44](#)
 C14077 [44](#)
 C14080 [44](#)
 Calculation of speed variations [17](#), [28](#)
 Conventions used [6](#)

D

DFIN (MXI1)
 Signal error enable/lamp control [49](#)
 Supply cannot be corrected anymore [49](#)
 Track error A-/A [49](#)
 Track error B-/B [49](#)
 Track error Z-/Z [49](#)
 DFIN (MXI2)
 Signal error enable/lamp control [50](#)
 Supply cannot be corrected anymore [50](#)
 Track error A-/A [50](#)
 Track error B-/B [50](#)
 Track error Z-/Z [50](#)
 DFOUT (MXI1)
 Maximum frequency reached [49](#)
 DFOUT (MXI2)
 Maximum frequency reached [50](#)
 Digital frequency input [9](#)
 Digital frequency output [21](#)

E

E-mail to Lenze [53](#)
 Encoder mounting dir. (DFIN) (C13015) [34](#)
 Encoder mounting dir. (DFIN) (C14015) [40](#)
 Encoder type DFIN (C13010) [33](#)
 Encoder type DFIN (C14010) [39](#)
 Error number
 0x00990000 [49](#)
 0x00990001 [49](#)
 0x00990002 [49](#)
 0x00990003 [49](#)
 0x00990004 [49](#)
 0x00990005 [49](#)

- 0x00aa0000 [50](#)
 - 0x00aa0001 [50](#)
 - 0x00aa0002 [50](#)
 - 0x00aa0003 [50](#)
 - 0x00aa0004 [50](#)
 - 0x00aa0005 [50](#)
- F**
- Fault messages [48](#)
 - Feedback to Lenze [53](#)
 - Frequency at DFIN (C13031) [34](#)
 - Frequency at DFIN (C14031) [40](#)
 - Frequency at DFOUT (C13071) [37](#)
 - Frequency at DFOUT (C14071) [43](#)
 - Frequency limitation DFOUT (C13053) [37](#)
 - Frequency limitation DFOUT (C14053) [43](#)
- I**
- Initialisation time DFIN (C13013) [33](#)
 - Initialisation time DFIN (C14013) [39](#)
- L**
- Layout of the safety instructions [8](#)
 - LS_DigitalFrequencyInput [18](#)
 - LS_DigitalFrequencyOutput [29](#)
 - LS_TouchProbeDFIN [20](#)
 - LS_TouchProbeDFOUT [31](#)
- N**
- No. of increments DFIN (C13011) [33](#)
 - No. of increments DFIN (C14011) [39](#)
 - No. of increments DFOUT (C13051) [36](#)
 - No. of increments DFOUT (C14051) [42](#)
 - Number of increments [24](#)
- P**
- Parameter list [32](#)
 - Position at DFIN (C13032) [34](#)
 - Position at DFIN (C14032) [40](#)
 - Position at DFOUT (C13072) [37](#)
 - Position at DFOUT (C14072) [43](#)
- R**
- Resp. to DFIN enable sig. miss. (C13041) [35](#)
 - Resp. to DFIN enable sig. miss. (C14041) [41](#)
 - Resp. to freq. limit. DFOUT (C13080) [38](#)
 - Resp. to freq. limit. DFOUT (C14080) [44](#)
 - Resp. to track monitoring DFIN (C13040) [35](#)
 - Resp. to track monitoring DFIN (C14040) [41](#)
 - Resp. to Vcc error DFIN (C13042) [36](#)
 - Resp. to Vcc error DFIN (C14042) [42](#)
- S**
- Safety instructions [8](#)
- Signal format DFIN (C13012) [33](#)
 - Signal format DFIN (C14012) [39](#)
 - Signal source DFOUT (C13050) [36](#)
 - Signal source DFOUT (C14050) [42](#)
 - Speed at DFIN (C13030) [34](#)
 - Speed at DFIN (C14030) [40](#)
 - Speed at DFOUT (C13070) [37](#)
 - Speed at DFOUT (C14070) [43](#)
 - Speed variations [17](#), [28](#)
 - System fault messages [48](#)
- T**
- Table of attributes [45](#)
 - TP delay time DFIN (C13021) [34](#)
 - TP delay time DFIN (C14021) [40](#)
 - TP delay time DFOUT (C13061) [37](#)
 - TP delay time DFOUT (C14061) [43](#)
 - Track monitoring DFIN (C13014) [33](#)
 - Track monitoring DFIN (C14014) [39](#)
- U**
- Unit (C13035) [34](#)
 - Unit (C13075) [38](#)
 - Unit (C14035) [40](#)
 - Unit (C14075) [44](#)
- Z**
- Zero pulse offset [24](#)
 - Zero pulse offset DFOUT (C13052) [36](#)
 - Zero pulse offset DFOUT (C14052) [42](#)