

## SCL/SCM TERMINAL STRIP

STOP	1
SIGNAL COMMON	2
0-10 VDC SPEED REFERENCE INPUT	5
SPEED POT POWER SUPPLY	6
DIGITAL INPUT REFERENCE	11
TB-13A FUNCTION SELECT	13A
TB-13B FUNCTION SELECT	13B
TB-13E FUNCTION SELECT	13E
4-20 mA SPEED REFERENCE INPUT	25
PROGRAMMABLE FORM A RELAY	16
	17

Shown below are two sample wiring diagrams including forward/reverse direction control. One shows a three-wire start/stop control using momentary contacts, and the other shows a 2-wire start/stop control using maintained contacts. Required parameter settings are also included.

### 3-WIRE START/STOP

Set Parameter 10 (TB-13A) to Start Reverse (07).

Set Parameter 12 (TB-13E) to Start Forward (06).

Set Parameter 17 (Rotation) to Forward and Reverse (02).

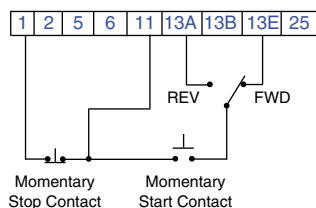

### 2-WIRE START/STOP

Set Parameter 10 (TB-13A) to Run Reverse (06).

Set Parameter 17 (Rotation) to Forward and Reverse (02).

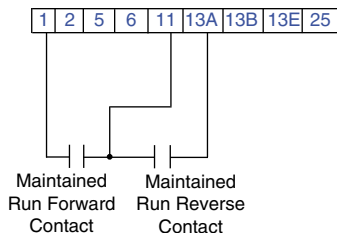

## DIAGNOSTIC AND DISPLAY MESSAGES

DISPLAY	DESCRIPTION
<i>Speed Reference Codes</i>	
CP	<b>CONTROL PAD:</b> The drive speed is controlled by the ▲ and ▼ buttons on the front of the drive.
EI	<b>EXTERNAL CURRENT:</b> The drive speed is controlled by a 4-20 mA signal between TB-25 and TB-2.
EU	<b>EXTERNAL VOLTAGE:</b> The drive speed is controlled by a 0-10 VDC signal between TB-5 and TB-2.
JG	<b>JOG:</b> The drive is in Jog mode and the speed is set by preset speed #2 (Parameter 32).
DP	<b>MOP:</b> Contacts wired to TB-13B and 13C are used to increase and decrease the drive speed.
Pr 1 - Pr 7	<b>PRESET SPEEDS #1-7:</b> The drive speed is set by the selected Preset Speed (Parameters 31-37).
<i>Status Indication</i>	
br	<b>DC BRAKING:</b> The DC braking function is activated.
CL	<b>CURRENT LIMIT:</b> The output current has exceeded the CURRENT LIMIT setting (Parameter 25) and the drive is reducing the output frequency to reduce the output current. If the drive remains in CURRENT LIMIT for too long, it can trip into a CURRENT OVERLOAD fault (PF).
Er	<b>ERROR:</b> Invalid data has been entered.
GE	"GE" will be displayed if an attempt is made to change the OEM default settings when the drive is operating in the OEM mode (see Parameter 48).
LC	<b>FAULT LOCKOUT:</b> Failed three restart attempts. Requires a manual reset.
SE	<b>SERIAL:</b> The optional remote keypad is active as the user interface instead of the buttons on the front of the drive.
SP	<b>START PENDING:</b> This is displayed during the 15 second interval between restart attempts.
<i>Diagnostic Codes</i>	
Hf	<b>HIGH TEMPERATURE FAULT:</b> Ambient temperature is too high.
Cf	<b>CONTROL FAULT:</b> A blank EPM, or EPM with corrupted data has been installed. Perform a factory reset (Parameter 48).
cF	<b>INCOMPATIBILITY FAULT:</b> An EPM with a different parameter version has been installed.
dF	<b>DYNAMIC BRAKING FAULT:</b> The drive has sensed the dynamic braking resistors are overheating.
Ef	<b>EXTERNAL FAULT:</b> TB-13A and/or TB13C is set as an external fault input and TB-13A and/or TB-13C is open with respect to TB-2.
Gf	<b>DATA FAULT:</b> User data and OEM defaults in the EPM are corrupted.
Hf	<b>HIGH DC BUS VOLTAGE FAULT:</b> Line voltage is too high; Deceleration rate is too fast; Overhauling load. Fast deceleration and overhauling loads may require dynamic braking.
Jf	<b>REMOTE KEYPAD FAULT:</b> The communication link between the drive and the optional Remote Keypad has been lost. Check for proper wiring and/or noise.
Lf	<b>LOW DC BUS VOLTAGE FAULT:</b> Line voltage is too low.
Of	<b>OUTPUT TRANSISTOR FAULT:</b> Phase to phase or phase to ground short circuit on the output; Failed output transistor; Boost settings are too high; Acceleration rate is too fast.
Pf	<b>CURRENT OVERLOAD FAULT:</b> VFD is undersized for the application; Mechanical problem with the driven equipment.
Sf	<b>SINGLE-PHASE FAULT:</b> Single-phase input power has been applied to a three-phase drive.
Uf	<b>START FAULT:</b> Start command was present when the drive was powered up. Must wait 2 seconds after power-up to apply Start command if START METHOD is set to NORMAL.
Fi	<b>EPM FAULT:</b> The EPM is missing or damaged.
Fc, F2-Fo	<b>INTERNAL FAULTS:</b> The control board has sensed a problem. Consult factory.

# AC Tech

member of the **Lenze** Group

Drive for Global Excellence

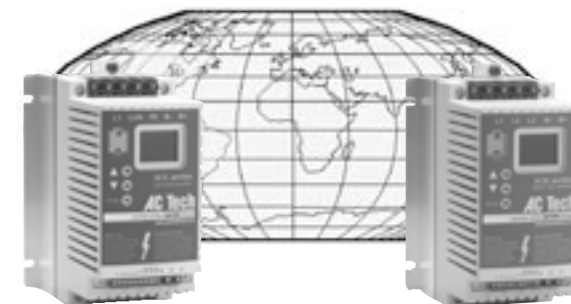

## SCL/SCM Series Quick Reference Guide

This guide is intended as an aid to configure the SCL and SCM Series drives.

**NOTE:** Before installing and operating the SCL or SCM drive, please read and become familiar with the SCL/SCM Series installation and operation manual.

## CONFIGURING THE SCL/SCM DRIVE

### Entering Program Mode:

To access the parameters, press the Mode button. This will activate the password prompt. The display will read "00" and the right-hand decimal point will be blinking. Use the ▲ and ▼ buttons to scroll to the password value (the factory default password is 225) and press Mode to enter.

Press **Mode**

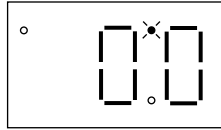

Display reads "00"

Upper right decimal point blinks

Use ▲ and ▼ to scroll to the password value (factory default password is 225)

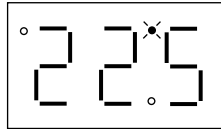

Press **Mode** to enter password

Once the PROGRAM mode is accessed, use the ▲ and ▼ buttons to scroll to the desired parameter number, and press the Mode button to see the parameter setting. Use the ▲ and ▼ buttons to change the parameter setting and press Mode to store the new setting.

### Connections:

Below is a sample wiring diagram for two-wire start/stop control. The drive is ready to use right out of the box, with these simple control wiring connections; no parameter adjustments are required. Speed is controlled from the ▲ and ▼ buttons on the front of the drive.

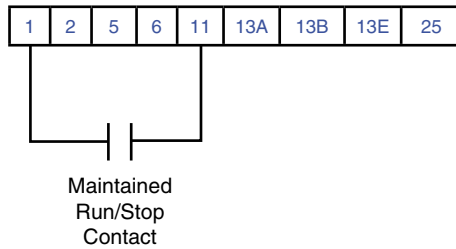

To add a potentiometer for speed control, change Parameter #5 (Standard Speed Source) to 0-10 VDC (03).

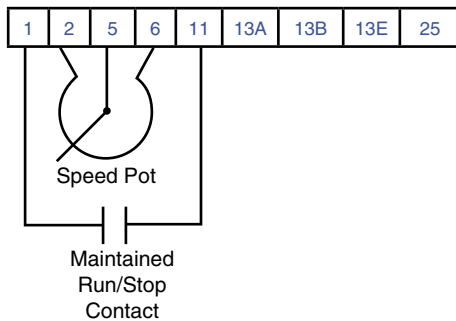

## SCL/SCM PARAMETER MENU

No.	Parameter Name	Range of Adjustment	Factory Default
01	Line Voltage	High (01), Low (02)	High (01)
02	Carrier Frequency	4 kHz (01), 6 kHz (02), 8 kHz (03), 10 kHz (04)	6 kHz (02)
03	Start Method	Normal (01), Start on Power-up (02), Start w/DC Brake (03), Auto Restart w/DC Brake (04), Flying Restart 1 (05), Flying Restart 2 (06), Flying Restart 3 (07)	Normal (01)
04	Stop Method	Coast (01), Coast with DC Brake (02), Ramp (03), Ramp with DC Brake (04)	Coast (01)
05	Speed Source	Keypad (01), Preset #1 (02), 0-10 VDC (03), 4-20 mA (04)	Keypad (01)
06	Relay Output	None (01), Run (02), Fault (03), Inverse Fault (04), Fault Lockout (05), At Set Speed (06), Above Preset #3 (07), Current Limit (08), Auto Speed (09), Reverse (10)	None (01)
10	TB-13A Select	None (01), 0-10 VDC (02), 4-20 mA (03), Preset Speed #1 (04), Start Forward (05), Run Reverse (06), Start Reverse (07), External Fault (08), Inverse External Fault (09), Auxiliary Stop (10), Accel/Decel #2 (11)	None (01)
11	TB-13B Select	None (01), 0-10 VDC (02), 4-20 mA (03), Preset Speed #2 (04), Decrease Freq (05), Start Forward (06), Jog Forward (07), Jog Reverse (08), External Fault (09), Inverse External Fault (10), Auxiliary Stop (11), Accel/Decel #2 (12), Remote Keypad (13)	None (01)
12	TB-13E Select	None (01), 0-10 VDC (02), 4-20 mA (03), Preset Speed #3 (04), Increase Freq (05), Start Forward (06), External Fault (07), Inverse External Fault (08), Auxiliary Stop (09), Accel/Decel #2 (10), Run (11), Fault (12), Inverse Fault (13), Fault Lockout (14), At Set Speed (15), Above Preset #3 (16), Current Limit (17), Auto Speed (18), Reverse (19), Dynamic Braking (20), Remote Keypad (21)	None (01)
14	Control	Terminal Strip Only (01), Remote Keypad Only (02),	Terminal Strip (01)
16	Units Editing	Tenths of Units (01), Whole Units (02)	Whole Units (02)
17	Rotation	Forward Only (01), Forward and Reverse (02)	Forward Only (01)
19	Acceleration Time	0.1 - 3600.0 sec	20.0 sec
20	Deceleration Time	0.1 - 3600.0 sec	20.0 sec

No.	Parameter Name	Range of Adjustment	Factory Default
21	DC Brake Time	0.0 - 3600.0 sec	0.0 sec
22	DC Brake Voltage	0.0 - 30.0%	0.0%
23	Minimum Frequency	0.0 - Maximum Frequency	0.0 Hz
24	Maximum Frequency	Minimum Frequency - 240.0 Hz	SCL = 50.0 Hz SCM = 60.0 Hz
25	Current Limit	30 - 180%	180%
26	Motor Overload	30 - 100%	100%
27	Base Frequency	25.0 - 500.0 Hz	SCL = 50.0 Hz SCM = 60.0 Hz
28	Fixed Boost	0.0 - 30.0%	1.0%
29	Accel Boost	0.0 - 20.0%	0.0%
30	Slip Compensation	0.0 - 5.0%	0.0%
31-37	Preset Speeds	0.0 - Maximum Frequency	0.0 Hz
38	Skip Bandwidth	0.0 - 10.0 Hz	0.0 Hz
39	Speed Scaling	0.0 - 6500.0	0
42	Accel / Decel #2	0.1 - 3600.0 sec	20.0 sec
44	Password	000 - 999	225
45	Speed at Min Signal	Minimum Frequency - 999 Hz	0.0 Hz
46	Speed at Max Signal	Minimum Frequency - 999 Hz	SCL = 50.0 Hz SCM = 60.0 Hz
47	Clear History	Maintain (01), Clear (02)	Maintain (01)
48	Program Selection	User Settings (01), OEM Settings (02), Reset OEM (03), Reset 60 (04), Reset 50 (05), Translate (06)	User Settings (01)
50	Fault History	View Only	(N/A)
51	Software Code	View Only	(N/A)
52	DC Bus Voltage	View Only	(N/A)
53	Motor Voltage	View Only	(N/A)
54	Load	View Only	(N/A)
55	0-10 VDC Input	View Only	(N/A)
56	4-20 mA Input	View Only	(N/A)
57	TB Strip Status	View Only	(N/A)
58	Keypad Status	View Only	(N/A)