

MC SERIES DYNAMIC BRAKING and ADDITIONAL FORM C RELAY OPTION

INSTALLATION INSTRUCTIONS (Manual Number: MDB01B)

- 1.0 INSTRUCTIONS FOR KITS:** DYNAMIC BRAKING: 842-001, 842-002, 842-005
 ADDITIONAL RELAY: 843-001, 843-006

0.5 - 5 HP @ 240 Vac
1 - 7.5 HP @ 480 Vac
1 - 5 HP @ 590 Vac

1.1 PARTS LIST

- | | |
|----------------------------------------------------------------------------------------------------------|--------------------------------|
| (1) Dynamic Braking Board (9935-XXX or 9956-XXX) or Additional Form C Relay Board (9934-XXX or 9956-XXX) | |
| (1) 7/16" Nylon sleeve standoff | |
| (2) Nylon "snap-in" standoff (7.5 Hp kits only) | (1) 3/4" Nylon sleeve standoff |
| (1) Resistor assembly (if ordered; DB kits only) | (1) Nylon shoulder washer |

1.2 PROCEDURE



DANGER!

Hazard of electrical shock! Remove power from the drive and wait three minutes before attempting this procedure. DC Bus capacitors retain charge after power is removed.



STOP!

The internal components of the MC Series drive can be damaged by electrostatic discharge (ESD)! Use an antistatic wrist strap with the ground clip attached to the drive ground lug when attempting this procedure. Always place components on antistatic surfaces or in antistatic bags when they are not being handled during this procedure.



Note

Refer to 1.4 Exploded View while performing this procedure. This view is from the right side of the drive. Be careful when removing and installing boards, as there are many pins that can be easily bent.

- With drive cover removed, remove the keypad assembly. On NEMA 1 units, this is done by prying one end of the bracket up and out. On NEMA 4 or 12 units, remove the screws that hold the bracket in place. Then unplug the keypad ribbon cable from the Main Control Board (9933A-XXX or 9019-XXX).
- Remove the Main Control Board by removing the four screws (one at each corner), and carefully lifting the board straight up and out. Remove the 1-5/16" nylon sleeve standoff from the lower left-hand corner screw, and replace it with the 3/4" nylon sleeve standoff from the kit. There is a 2 x 6 pin connector that connects the P3 plug on the Main Control Board to the P3 plug on the Power Board below. Leave this plugged into the P3 plug on the Power Board.
- Under the Main Control Board is the Driver Board (9926-XXX) which must be removed to install the DB Board or Relay Board. Remove the Driver Board by pinching the flared top of each nylon standoff while gently lifting up on the board (leave the standoffs snapped into the Power Board underneath).



Note

On 7.5 Hp, 480 Vac drives only, remove and save the 2 x 6 pin connector that is plugged into PL2 on the Driver Board (another 2 x 6 connector may be included in the DB kit; only one is needed).

- Slide the nylon shoulder washer through the 3/16" hole near the lower left-hand side of the DB Board or Relay Board, and slide the 7/16" nylon sleeve standoff onto the shoulder washer from the bottom side of the board.
 NOTE: On 9956-XXX boards (kits 842-005 and 843-006), install the two nylon "snap-in" standoffs into the holes near the DB1 and DB2 terminals.
- Snap the DB Board or Relay Board into place where the old Driver Board was, onto the same nylon standoffs that held the Driver Board in place. **Make sure that the PL1 pin connector (and the P8 and P9 spade connectors on DB Boards) makes positive contact with their respective plugs.**
For 9956-XXX board (kits 842-005 and 843-006): this board will also have a P11 connector on the bottom of the board. **Make sure that the P11 connector makes positive contact to the pins on the Power Board below. Install the 2 x 6 pin connector in PL2.**
- Re-install the Main Control Board. **Make sure that the PL2 and P3 pin connectors make positive contact through the bottom of the Main Control Board.**
- Re-install the keypad assembly and drive cover.

1.3 WIRING AND PROGRAMMING

Refer to the appropriate diagram to the right for wiring.

To enable Dynamic Braking, set DYN BRAKE (parameter 14) to ON.

To enable the Additional Form C Relay, set TB-14 OUT (parameter 52) to the desired status indication.

Refer to the drive's Installation and Operation Manual for more info on programming.

For Kit 842-005: This Dynamic Braking board for 7.5 Hp, 480 Vac drives also contains the Additional Form C Relay option.

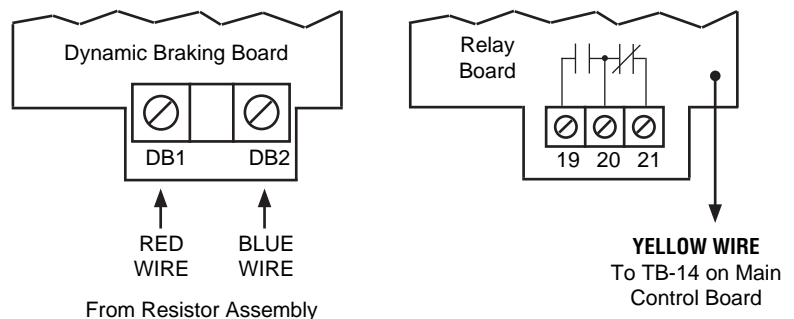

Lenze

1.4 EXPLODED VIEW

Applies to kits: 842-001, 842-002, 842-005
843-001, 843-006



Note
Dynamic Braking Board is shown for illustration purposes. The Additional Form C Relay Board is very similar and the installation procedure is the same.

0.5 - 5 HP @ 240 Vac
1 - 7.5 HP @ 480 Vac
1 - 5 HP @ 590 Vac

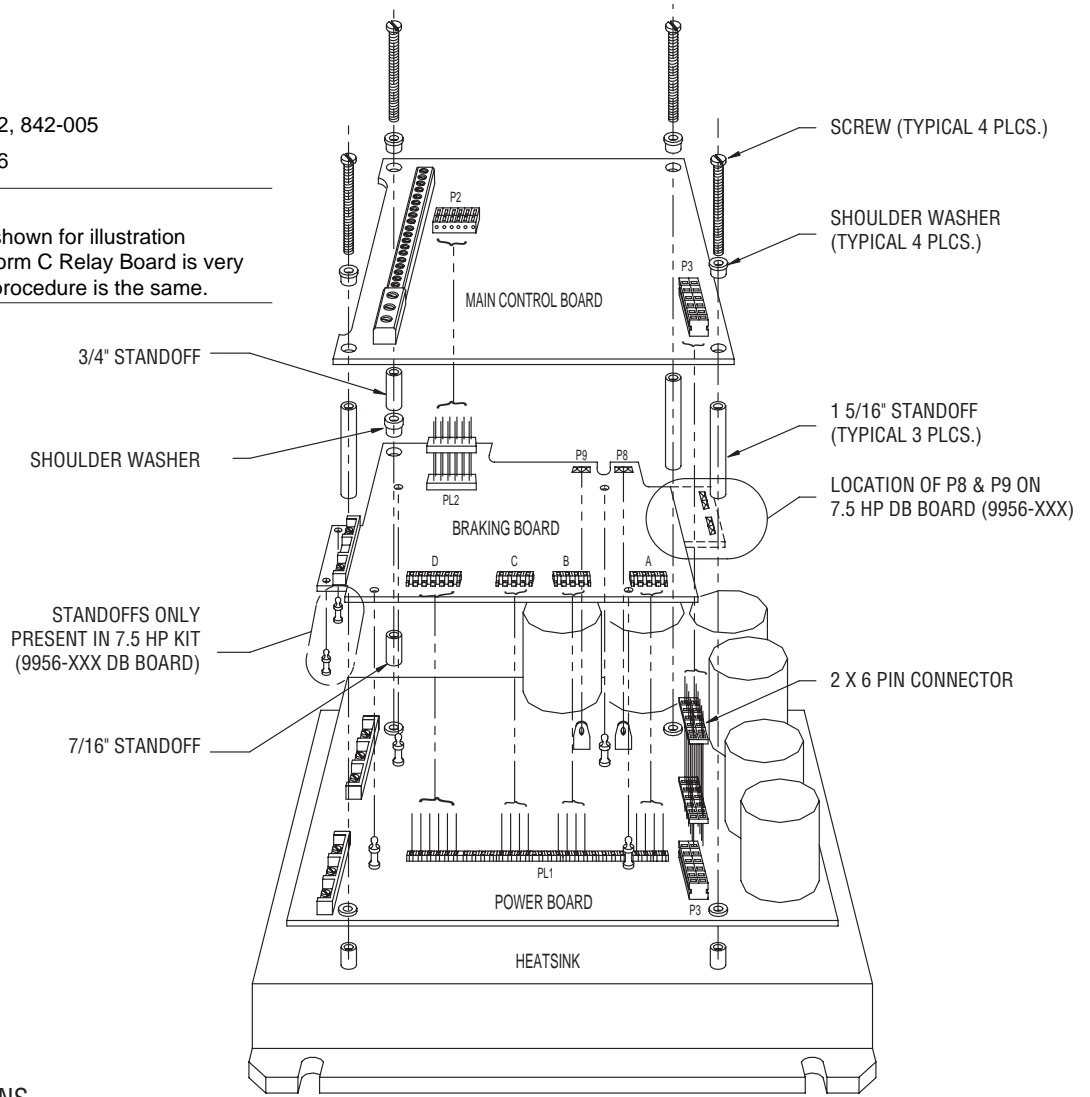

1.5 RESISTOR CONFIGURATIONS

When the Dynamic Braking Kit is ordered separately from the MC Series drive, the resistor assembly will be shipped in the 480 Vac and 590 Vac configuration. For 240 Vac units, the resistor configuration must be modified, as shown below, using the hardware included with the kit.



Note
If the Dynamic Braking option is ordered with the drive, the resistor assembly will be shipped in the proper configuration, and no modification is required

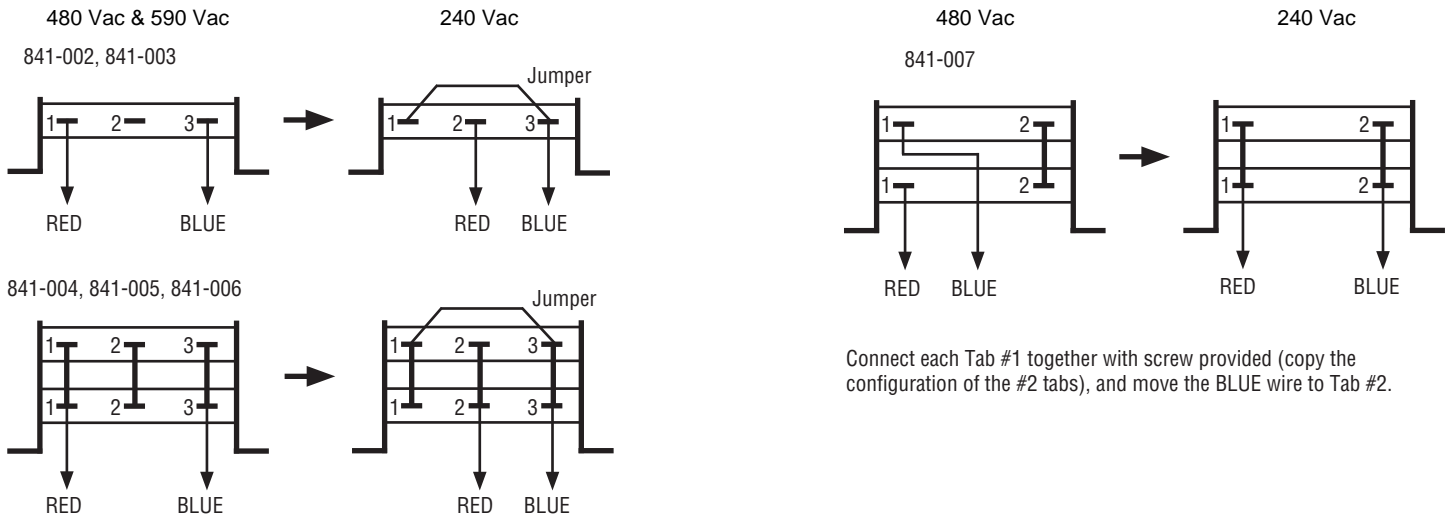

Connect each Tab #1 together with screw provided (copy the configuration of the #2 tabs), and move the BLUE wire to Tab #2.

Add jumper between Tab #1 and Tab #3, and move the RED wire to Tab #2.

Lenze

2.0 INSTRUCTIONS FOR KITS: DYNAMIC BRAKING: 842-006, 842-007
 ADDITIONAL RELAY: 843-007, 843-008

1.1 PARTS LIST

- | | |
|--------------------------------------|------------------------------------|
| (1) Dynamic Braking Board (9955-XXX) | (1) Resistor assembly (if ordered) |
| (2) Screw with captive lock washer | (2) Metal "male-female" standoff |
| (2) Large flat washer | (2) Small flat washer |
| (2) Lockwasher | (2) Nylon "snap-in" standoff |

2.2 PROCEDURE



DANGER!

Hazard of electrical shock! Remove power from the drive and wait three minutes before attempting this procedure. DC Bus capacitors retain charge after power is removed.



STOP!

The internal components of the MC Series drive can be damaged by electrostatic discharge (ESD)! Use an antistatic wrist strap with the ground clip attached to the drive ground lug when attempting this procedure. Always place components on antistatic surfaces or in antistatic bags when they are not being handled during this procedure.



Note

Refer to 2.4 Exploded View while performing this procedure. This view is from the right side of the drive.
 Be careful when removing and installing boards, as there are many pins that can be easily bent.

- With the drive cover removed, remove the keypad assembly. On NEMA 1 units, this is done by prying one end of the bracket up and out. On NEMA 4 or 12 units, remove the screws that hold the bracket in place. Then unplug the keypad ribbon cable from the Main Control Board (9933A-XXX or 9019-XXX).
- Remove the Main Control Board by unscrewing the four screws (one at each corner) and lifting the Main Control Board straight up and out. There is a 2 x 6 pin connector that connects the P3 plug on the Main Control Board to the P3 plug on the Power Board below. Leave this plugged into the P3 plug on the Power Board.
- Under the Main Control Board is the Driver Board (9941-XXX) which must be removed to install the DB & Relay Board. Remove the Driver Board by pinching the flared top of each nylon standoff while gently lifting up on the board (leave the standoffs snapped into the Power Board underneath). Remove and save the 2 x 6 pin connector (see 2.4 Exploded View) that is plugged into PL2 on the Driver Board (another 2 x 6 pin connector may be included in the DB & Relay kit; only one is needed).

Once the Driver Board is removed, examine the Power Board. There will be three screws in a row between the Bus Capacitors and the PL1 connector. Some units will also have two standoffs labeled "P" and "B" located below the row of screws. If the Power Board has the "P" and "B" standoffs, go to Step 6. If not, continue with Step 4.

- There are three screws in a horizontal row located between the Bus Caps and the PL1 connector on the Power board. Remove and discard the middle and right screws (which are the middle and bottom screws as viewed in 2.4 Exploded View).
- Install the two metal "male-female" standoffs where the screws were removed in Step 5, using the large flat washers and lockwashers.
- Install the two nylon "snap-in" standoffs into the holes near the DB1 and DB2 terminals.
- Snap the DB & Relay Board into place where the old Driver Board was, onto the same nylon standoffs that held the Driver Board in place. **Make sure that the PL1 and PL3 pin connectors make positive contact through the bottom of the DB & Relay Board.**
- Install the two screws with captive lockwashers at the top of the DB & Relay Board at the positions marked "P" and "B", using the small flat washers.
- Install the 2 x 6 pin connector in PL2 on the DB & Relay Board.
- Re-install the Main Control Board. **Make sure that the PL2 and P3 pin connectors make positive contact through the bottom of the Main Control Board.**
- Re-install the keypad assembly and drive cover.

2.3 WIRING AND PROGRAMMING

Refer to the diagram to the right for wiring.

To enable Dynamic Braking, set DYN BRAKE (parameter 14) to ON.

To enable the Additional Form C Relay, set TB-14 OUT (parameter 52) to the desired status indication.

Refer to the drive's Installation and Operation Manual for more info on programming.

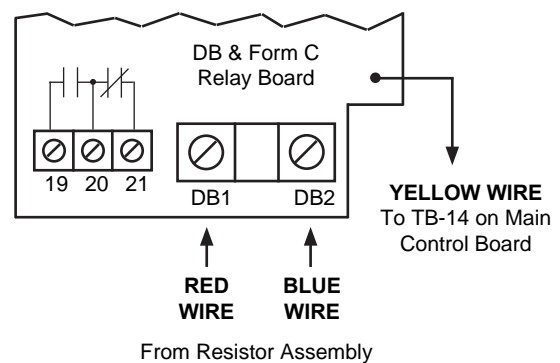

2.4 EXPLODED VIEW

Applies to kits: 842-006, 842-007
843-007, 843-008



Note

Dynamic Braking Board is shown for illustration purposes. The Additional Form C Relay Board is very similar and the installation procedure is the same.

7.5 - 30 HP @ 240 Vac

10 - 60 HP @ 480 Vac

7.5 - 60 HP @ 590 Vac

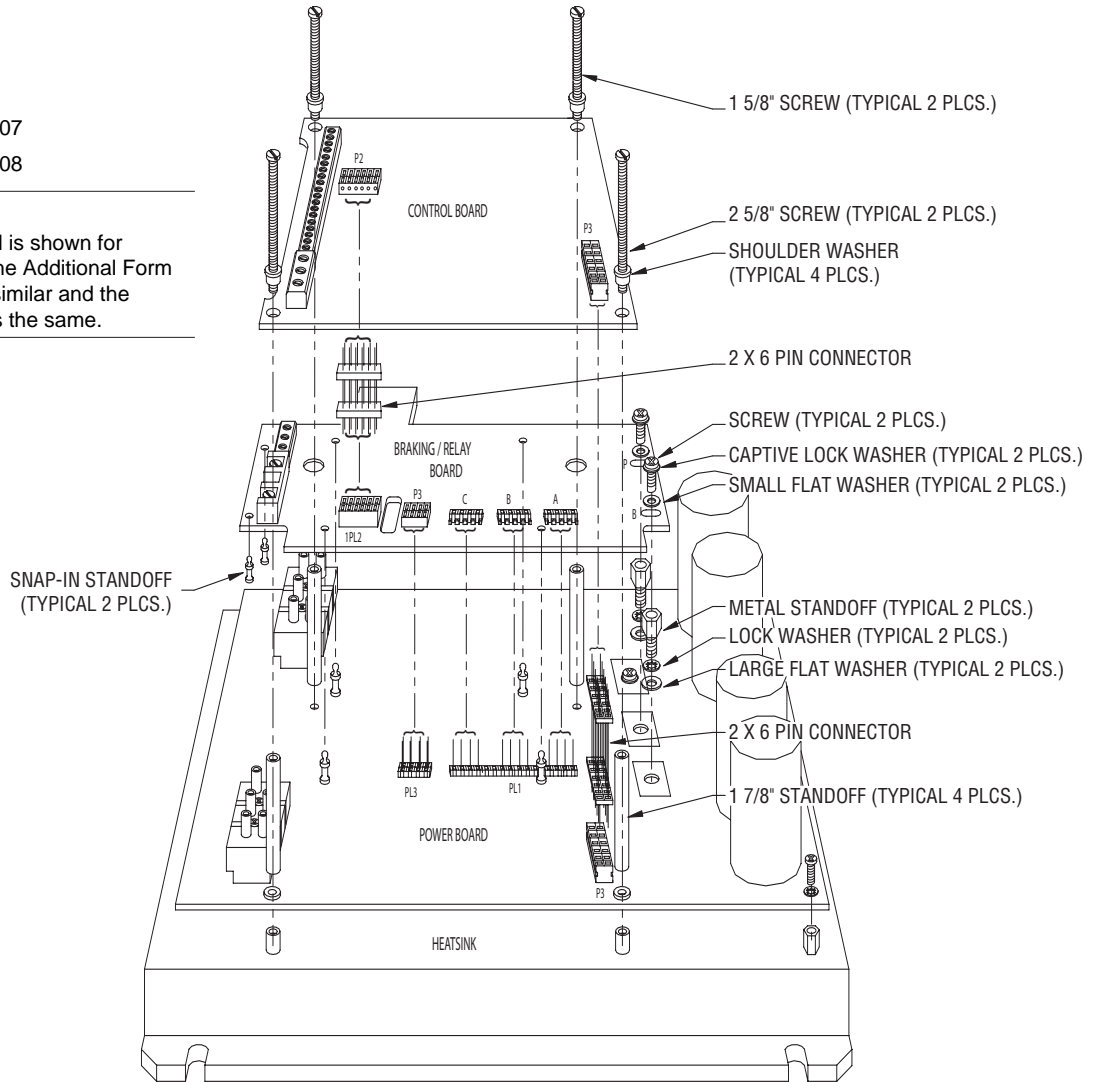

2.5 RESISTOR CONFIGURATIONS

When the Dynamic Braking Kit is ordered separately from the MC Series drive, the resistor assembly will be shipped in the 480 Vac and 590 Vac configuration. For 240 Vac units, the resistor configuration must be modified, as shown below, using the hardware included with the kit.



Note

If the Dynamic Braking option is ordered with the drive, the resistor assembly will be shipped in the proper configuration, and no modification is required.

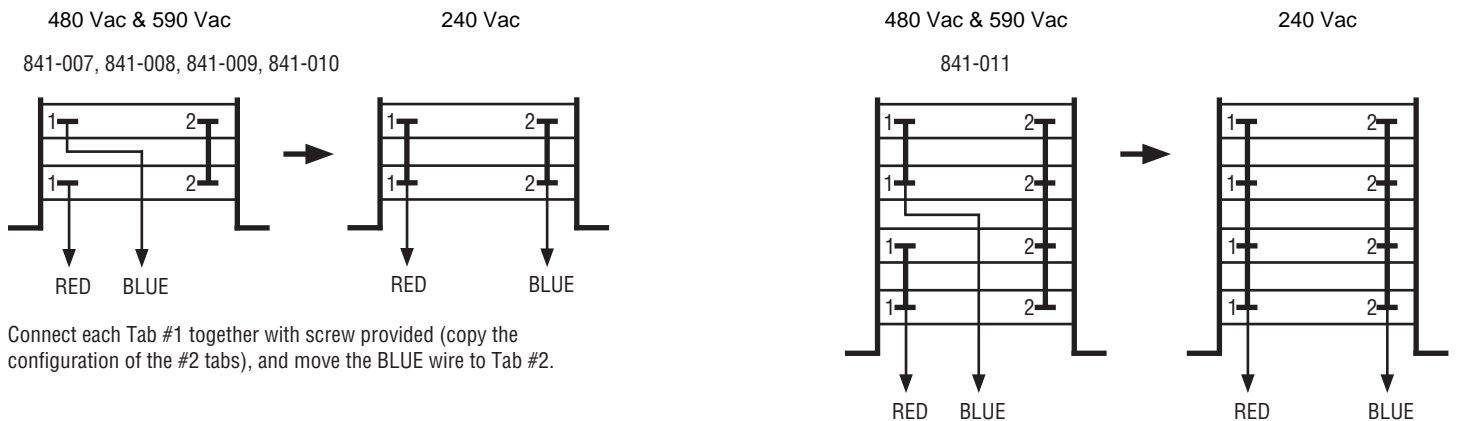

Connect each Tab #1 together with screw provided (copy the configuration of the #2 tabs), and move the BLUE wire to Tab #2.

Connect each Tab #1 together with screw provided (copy the configuration of the #2 tabs), and move the BLUE wire to Tab #2.